



User Manual

TDX Headend System Main Unit Black Edition

Model		Item no.	
TDX Headend System Main Unit – Black edition		492091	
Version	891072C	Date	01/2017
		EN	

triax.com

Safety Precautions	3
Environment	3
Power supply	3
Weight	3
Earth	3
Disposal	3
Black Edition – what’s new	4
New features in Black edition	4
New user interface (GUI) – what has changed	4
Service Agreement	4
Fixed PID, filter + remap	4
Introduction.....	5
Box contents	5
Exterior	5
Interior.....	5
Single headend installation	7
Mounting	7
Ventilation requirements	7
Power / Earth / ID switch.....	7
Multi Headend installation.....	8
RF output.....	8
Power	8
Ventilation requirements	8
1. Horizontal.....	8
2. Vertical	8
Connection units – direct connection.....	9
1. 1x Main – 1x sub.....	9
2. 1x Main – 2x sub.....	9
Connecting units – switch connection	10
Multi headend installation – Fiber optic	10
Resetting IP address.....	10
Input modules.....	11
Input module types	11
Inserting input modules.....	11
Attaching cables	12
Looping cables.....	12
Removing input modules.....	12
Moving input modules	12
Output modules	13
Output module types	13
Inserting output module	13
Removing output module	13
Auxiliary modules	13
System monitoring.....	14
Input modules – LED status	14
Output modules – LED status	14
Service tool - System requirements.....	15
Computer minimum requirements.....	15
Static IP address.....	15
Starting service tool.....	16
Overview.....	16
Tabs.....	17
Communication circle	17
System icons.....	17
Misc. buttons	17
Configuration buttons.....	17
Administration.....	17
Language	18
Location	18
Time zone	18
Time set by NTP server	19
Security	19
Features and License Keys	20
How-To get License Keys.....	20
IP settings	21
SNMP settings	22
CAS server settings	23
Rebooting.....	23
View system log.....	23
Firmware updating.....	24
Firmware clean up	24

Format file system in flash.....	25
Force TDX systemcontroller in failsafe mode.....	25
Reinitialize SD card.....	25
IP out service list.....	26
System information.....	27
Viewing system information.....	27
Duplicated PID's.....	27
Managing configuration files.....	28
Creating.....	28
Activating.....	28
Deleting.....	28
Saving.....	28
Uploading.....	29
IP Input configurations.....	30
Creating.....	30
Specifying EIT/EPG source.....	31
Specifying Alternative EIT/EPG source.....	31
EIT for Viasat services.....	32
Modifying.....	32
Deleting.....	32
IP output configurations.....	32
Creating.....	33
Modifying.....	34
Deleting.....	34
EIT/EPG output.....	34
EIT – every IP service.....	35
EIT – barker channel.....	35
PID handling.....	36
SNMP traps.....	38

Safety Precautions

Environment

- Operating temperature -10 C to +50 C.
- Storage temperature -20 C to + 70 C.
- Max. Operating humidity 80% (RH).
- Max. Storage humidity 90% (RH).

Power supply

The input voltage must be 190-264 VAC. ~ 45/65 Hz / 280 W (Max).
 Use only power connections installed by professionals.

Weight

- Minimum weight 10.5 kg
- Maximum weight 13.8 kg*

Earth

Headend units must be correctly earthed according to applicable national regulations.

Disposal



This product may not be disposed of with general household waste.
 Follow applicable national legislation when disposing of this product.

Attention !

EN Failure to comply with the specified precautionary measures may cause serious injury to persons or damage to property. The installation and commissioning may only be performed by suitably qualified persons, technicians or installers in compliance with safety regulations. Damage due to improper installation and commissioning, defective connectors on cables or any other incorrect handling will void the warranty.

CAUTION: The safety requirements are according to EN 60728-11 and must be observed.

Disconnect mains power before working on electrical systems.

Any additional electrical wiring requirements should always be installed by a suitably qualified person(s).

Installation or service work should NEVER be undertaken during electrical / thunderstorms.

Black Edition – what's new

New features in Black edition

New features have been implemented in the Black edition:

- From S/W edition 4.0.1 the user interface (GUI) has been updated – more clear, more understandable and more easy in use; entirely based on HTML5
- A Service level agreement (SLA) is introduced for dedicated service and customer/end user satisfaction. The SLA comes in 3 levels.
- New fixed PID feature that can be filtered and remapped.
- Fan noise has been reduced by 3dB

New user interface (GUI) – what has changed

In the new GUI there has been following changes

- New updated GUI – more clear, more understandable and more easy in use; and its written in HTML 5
- Port forwarding, for remote control – prior to this new S/W release, you had to use
 - Port 80, 943, 4530, 4531In the new GUI **only port 80** is required – much more simple and secure to setup remote management. Due to this, the remote management is useable both on PC, tablet and smartphone. The new GUI have been tested on the following browsers:
 - Mozilla firefox ver. 46.0.1 or newer
 - Google Chrome ver. 50.0.2661 or newer
 - MS internet explorer 11 ver. 11.0.9600.18314 or newer
- The new GUI reports if the software is registered or not
- The ADMIN button has slightly changed position
- Navigation information has replaced the BACK button
- Highlighted information and more clear warnings, etc.
- New failsafe image – never lose your setup.

Service Agreement

TRIAX Service Agreement, the safe & sound deal, comes in 3 levels – Pay-As-You-Go, BASIC and PLUS.

The TRIAX Service Agreement ensures your solutions are always up and running, always up to date and always backed up by the best service and support; helping you operate a professional and profitable business.

Your Service Agreement benefits:

- Supported Setup, including free of charge 30 day installation period with unlimited access to features.
- Supported installations and solutions.
- Easy online access to the Trouble Ticket System, Product Registration Tool, new SW versions, release notes, new License Keys, how-to guides and much more.

Fixed PID, filter + remap

The PID (Packet identifier) handling has been changed significantly

- Fixed PID – the PID value is now fixed at the output after a reset of the TDX system
- PID filter – the elementary streams can now be removed from output of the TDX system
- PID remap – the PID value can now be changed at the output of the TDX system

Introduction



The TDX cabinet is designed to accommodate up to 16 input modules and 6 quad output modules. Up to three TDX headends can be combined as one system of up to 48 input muxes and 72 output channels.

The TDX headend system accommodates up to 490 services. All incoming signals from input modules initially arrive in the TDX service-pool, where conversion to defined output signals occurs, after which the converted signals are fed to output modules.

Box contents

- TDX headend unit,
- 1 x TDX Key 775310
- 2 x Mounting brackets 775285
- 4 screws (M4 x 8 hexagon ISO 7380) 840200)
- 1 x Torx® key (2.5 mm) 848603
- 1 x Power cord
- User guide.

Exterior

- (A) Input module area
- (B) Output module area
- (C) Mounting brackets
- (D) Lock
- (E) Headend status LEDs

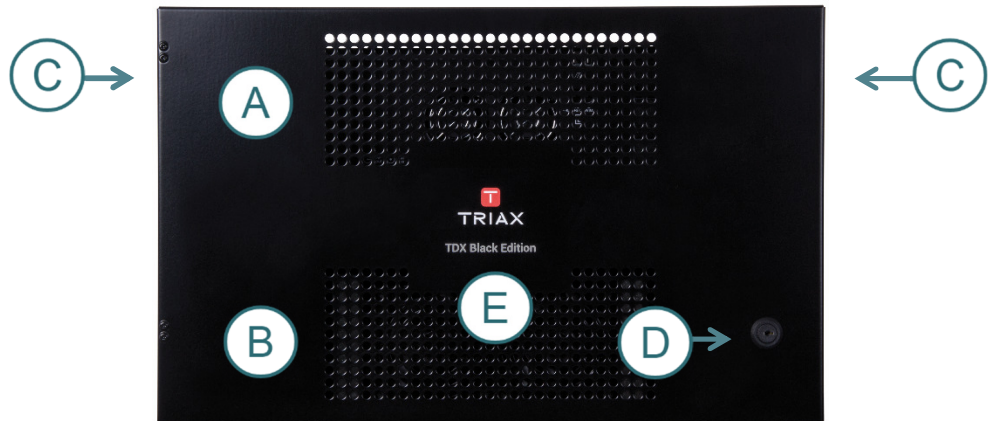

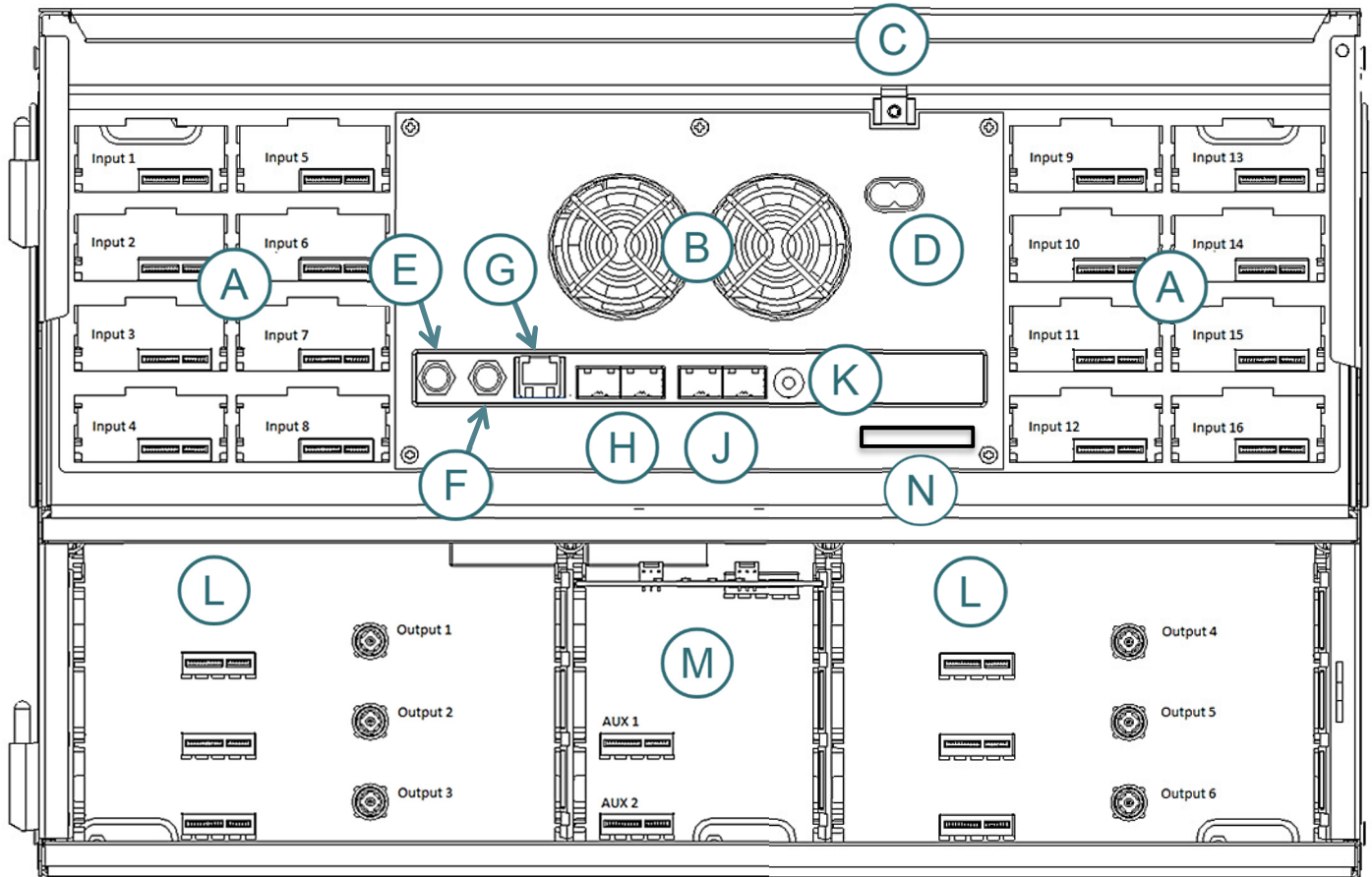

(A)	input slots (16 in total)	(H)	AUX 1 & 2	Distributes services from IP output modules
(B)	Extractor fans	(J)	Link 1 & 2	Connects the main unit with subunits 1 and 2. Can also be used in conjunction with IP input and output
(C)	Earth terminal	(K)	ID switch	Switch for setting the ID of the main unit and the two subunits
(D)		(L)	Output slots (6 in total)	
(E)	RF output	(M)	Slot 1 & 2 for auxiliary boards	Auxiliary boards are used in connection with IP output modules
(F)	Test point -20dB	(N)	Secure Digital (SD card)	Memory card for storage of the system configuration (behind panel)
(G)	Configuration port			Ethernet configuration port for setting up the headend unit

Single headend installation

Mounting

The headend can be mounted either on a system rack or directly onto a wall.



Rack installation



Wall installation

1. Attach the mounting brackets to the headend with the supplied screws.
Rack: At the front of a headend
Wall: At the rear of a headend
2. Attach the headend to the wall or onto a system rack

Ventilation requirements

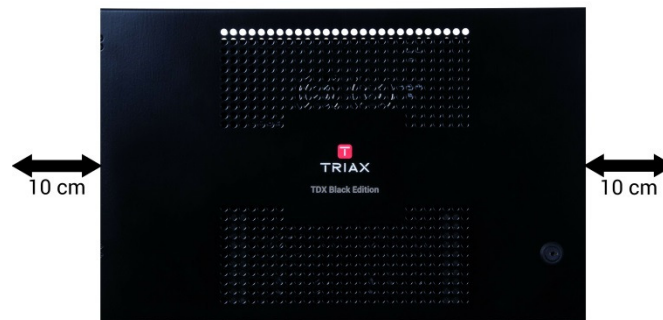

1. Ensure that min. 10cm ventilation space is available on both sides and the front of the headend
2. Insert the key into the headend
3. Open the door
4. Lift the door off its hinges (optional)
5. Remove the top cover (optional)

Power / Earth / ID switch

1. Connect an earth cable to Earth terminal
2. Attach the other end of the earth cable to an approved earth connection point
3. Insert the supplied cable into the Power Input port
4. Confirm that the ID switch is set to "0"

Multi Headend installation

Up to three headends can be combined to further increase the number of services provided. The headends are physically installed as per installation of single headend, i.e. by using the supplied brackets described above. The headends can be combined in either "direct connection" or "switch connection"

RF output

Connect each headend unit to a combiner using RF cables from the RF output socket to the combiner.

Power

1. Connect each headend unit to an approved 'earth' connection point.
2. Provide power to each headend unit with the supplied power lead.

Ventilation requirements



Ensure that the following ventilation requirements are met:

1. Horizontal



- Min. 20cm ventilation space must be available between headends.
- Min. 10cm ventilation space must be available outside the end headends.
- Min. 10cm ventilation space must be available from the front of each headend.

2. Vertical

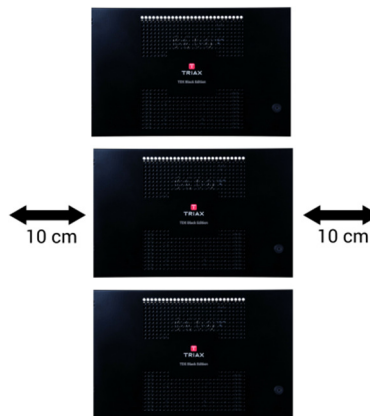

- 10cm ventilation space must be available on both sides of each headend.
- 10cm ventilation space must be available from the front of each headend.

Connection units – direct connection

Note that direct connection hardware configurations require the **Connection type** field in the service tool's Admin/IP Settings/Setup window to be set to 'Direct'

1. 1x Main – 1x sub

1. Insert SFP copper transceivers into the "Link 1" sockets on the main headend and subunit headend.
2. Route a RJ45 Cat5e or better cable from the "Link 1" socket on the main unit to the "Link 1" socket on subunit 1.
3. Set the "ID switch" on the main headend and subunit headend to the following:
 - Main unit = "3"
 - Subunit = "1"

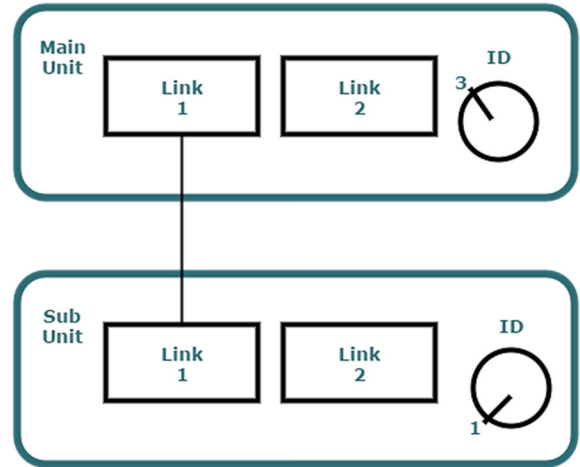

a.

2. 1x Main – 2x sub

1. Insert SFP copper transceivers into the "Link 1" and "Link 2" sockets on the main headend and subunit headends.
2. Route a RJ45 Cat5e or better cable from the "Link 1" socket on the main unit to the "Link 1" socket on subunit 1.
3. Route a RJ45 Cat5e or better cable from the "Link 2" socket on the main unit to the "Link 1" socket on subunit 2.
4. Route a RJ45 Cat5e or better cable between the "Link 2" sockets on both subunits.
5. Set the "ID switch" on the main headend and subunit headends to the following:
 - Main unit = "3"
 - Subunit 1 = "1"
 - Subunit 2 = "2"

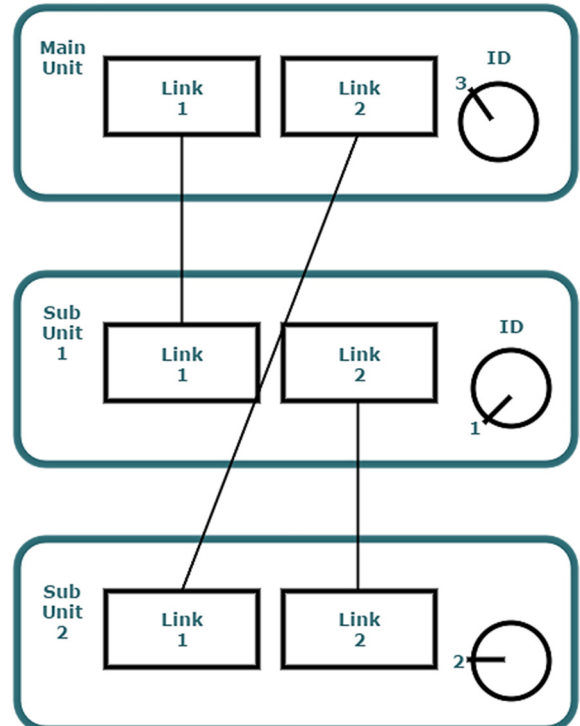

Connecting units – switch connection

Note that headend units connected using a network switch require the **Connection type** field in the service tool's **Admin /IP Settings /Setup** window to be set to **Switch**.

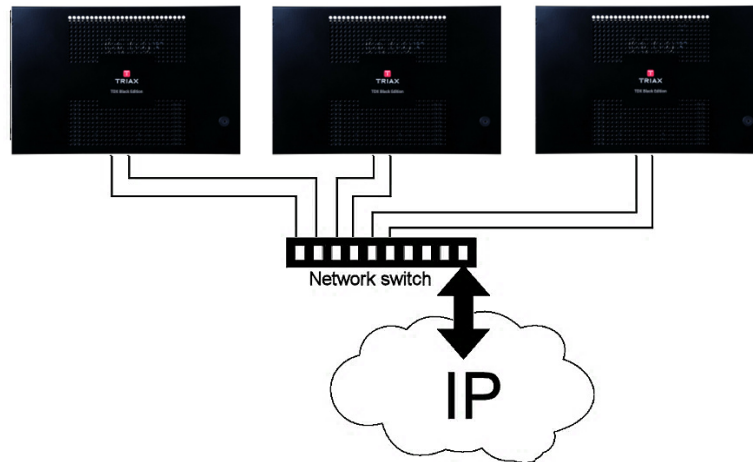

Triax recommends that a network switch is used for connecting the main and subunits even if IP services are not currently supported. The network switch used must support IGMP ver. 2 and contain a sufficient number of ports to connect to the Link sockets on the main and subunits.

1. Insert SFP copper transceivers into the "Link 1" and "Link 2" sockets on the main headend and subunit headend(s).
2. Route a RJ45 Cat5e or better cable from the "Link 1" socket on the main unit and subunit(s) to the network switch.
3. Route a RJ45 Cat5e or better cable from the "Link 2" socket on the main unit and subunit(s) to the network switch.
4. Set the "ID switch" on the main headend and subunit headends to the following:
 - a. Main unit = "3"
 - b. Subunit 1 to "1"
 - c. Subunit 2 (if present) to "2"
5. Connect the network switch to the IP network.

Multi headend installation – Fiber optic

Fiber-optic cables must be used to connect the main headend unit to one or two subunits over distances greater than 100m. The following SFP fibre-optic transceivers must be used in the Link sockets:

492087	Fiber (850nm) (LC)	1000Mbps	550m	Gigabit Ethernet
492088	Fiber (1310nm) (LC)	1000Mbps	2km	Gigabit Ethernet

Resetting IP address

The IP address of a headend unit can be returned to the factory default address by using the ID switch.

1. Turn off the power to the main unit.
2. Set the ID switch on the main unit to "7".
3. Turn on the power.

The four LEDs flash red and yellow until the process of resetting the IP address has been completed.

The LEDs show green-constant if the reset process was successful.

1. Turn off the power to the main unit.
2. Set the ID switch on the main unit back to the initial setting.
3. Turn on the power to the main unit.

The IP address has been reset to the factory default (192.168.0.100)

Input modules

16 input modules can be installed per headend unit. Hot swap technology is used in the headend, meaning that modules can be inserted/removed/moved when the headend is in operation.

Input module types

Each input module is identified through the use of a specifically coloured label. The label also indicates the module type's name and associated item number. The remainder of the label is used for noting post-installation module information. Another label containing a barcode and serial number is located on the underside of the input module.

Name	DVB-C input module
Item number(s)	492024
Label colour	Crimson
Name	HDMI input module
Item number(s)	492030
Label colour	Orange
Name	A/V input module
Item number(s)	492080
Label colour	Yellow
Name	DVB-S/DVB-S2 input module
Item number(s)	492020
Label colour	Light blue
Name	DVB-T/DVB-T2 input modules
Item number(s)	492022, 492023
Label colour	Purple

Inserting input modules

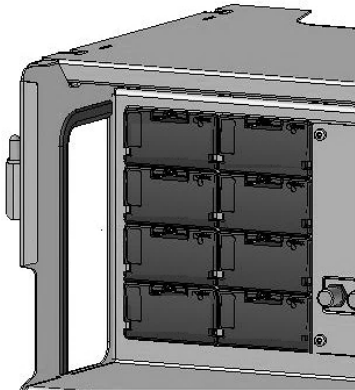

- Prize the protective cover away from an available input slot.
 - Retain the protective cover.

Note: Any available input slot can be used

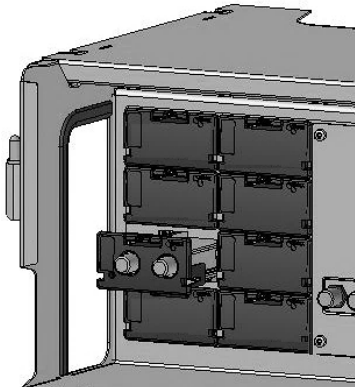

- Push the input module into the input slot until the input module is locked in position.
- Note details for the input module on the label (optional).
- Note details for the input module on the label located inside of the door (optional).
- Continue inserting all additional input modules.

Attaching cables

Signal cables can be attached when all input modules have been installed.

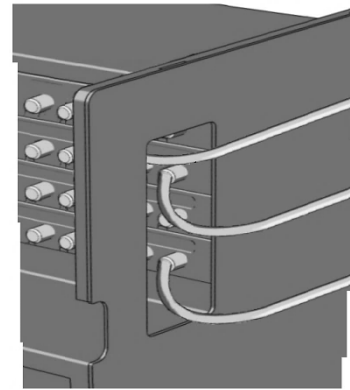
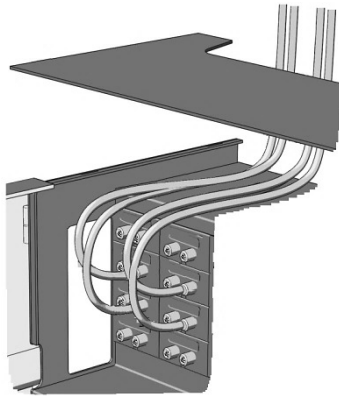

1. Route the cables either through the cable openings on the top or on the sides of the headend.
2. Attach the signal cables to the 'IN' connector on the input module.

Note: Ensure that enough cable is available for relocating input modules to alternate input slots at a later date.

Looping cables

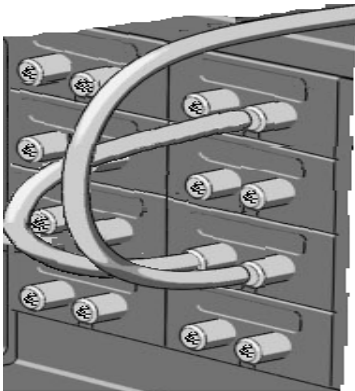

DVB-S/S2 signals can be looped between input modules:

1. Attach the signal cable to the IN port on one DVB-S/S2 input module.
2. Attach a loop cable to the OUT port on the same DVB-S/S2 input module.

Attach the other end of the loop cable to the IN port on another DVB-S/S2 input module.*

Removing input modules

Input modules are removed from the headend by:

1. Remove the signal cable from the module.
2. Prize the module out of the headend with a flathead screwdriver.
3. Pull the module out of the headend.

Note:

Modules can be removed while the headend is in operation.

Moving input modules

1. Prize the module out of the headend with a flathead screwdriver.
2. Pull the module out of the headend.
3. Insert the module in a new input slot.

Note:

Modules can be moved while the headend is in operation.

Output modules

Six output modules, each consisting of four RF channels can be installed in a headend unit. Hot Flash technology is used in the headend, meaning that output modules can be inserted/removed/moved while the headend is running.

Output module types

Each output module is identified through use of a specifically coloured label. The label also indicates the module type's name and associated item number. The remainder of the label is used for noting post-installation module information. Another label containing a barcode and serial number is located on the underside of the output module.

Name	QAM FTA/CI output module
Item number(s)	492055/492056
Label colour	Purple
Name	PAL FTA/CI output module
Item number(s)	492050/492051/492052/492053
Label colour	Green
Name	COFDM FTA/CI output module
Item number(s)	492060/492061
Label colour	Orange
Name	2xCI Slots output module
Item number(s)	492070
Label colour	Black
Name	IP 2xCI output module
Item number(s)	492072
Label colour	Black

Note: Some output modules also contain slots for two CAM modules

Inserting output module

Depending on where you want to insert the output module push the extractor fan to the opposite side.

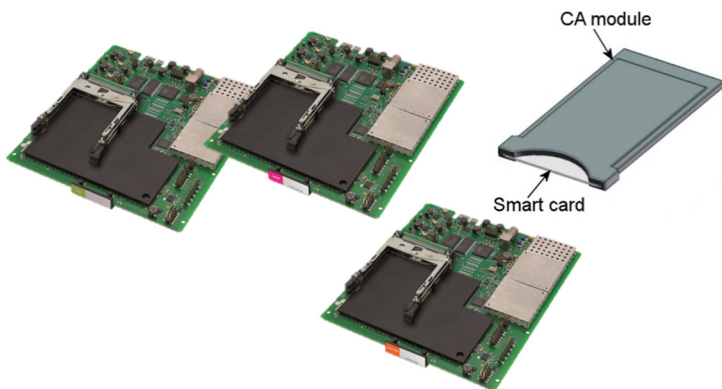

1. Insert smart cards (if relevant).
 - Insert the service provider's smartcard into the CA module.
 - Insert the CA module into either of the available slots in the output module.
2. Push the output module into an available output slot.
3. Press until the output module is locked into position.
4. Continue inserting all additional output modules.
5. Note details about the output module on the label (optional).
6. Note details about the output module on the label located on the inside of the door (optional).
7. Return the extractor fan to the centre of the output area.

Removing output module

1. Release the lock mechanism on the module to be removed.
2. Extract the module from the headend.
3. Return the extractor fan to the center of the output area.

Auxiliary modules

Two slots are present in the middle of the output section for installation of auxiliary modules. For details refer to products that use auxiliary boards.

System monitoring

Input modules – LED status

Each input module has an LED on the front to indicate its current status when the headend is powered:

Green - flashing	The module is yet to be configured yet.
Green	No errors, and the tuner is locked to the frequency.
Red	Error, and the tuner is not locked to the frequency.
No colour	Module is not powered.

Input module software updates are also displayed on the LED when the modules are updating:

Orange	Booting.
Temporary off	Initiation of the software update.
Temporary green	Every time the module receives a valid data package. Repeated until the update is completed without errors.
Red	Software update failed.

Output modules – LED status

Four LEDs are placed at the top of the output section of each headend unit, and provide information on the state of the headend and subunits (if present).

The four LEDs are named (from left to right):

System Status	Tuner Status	Unit Link 1	Unit Link 2
----------------------	---------------------	--------------------	--------------------

The LEDs can be green - constant, green – flashing, red, or no colour is displayed. The message being indicated are different for each LED.

Headend type/usage	LED Name	Colour	Message
Standalone	System Status	Green – constant	Power is on and the headend is operational.
		Green – flashing	The headend is booting up.
		Red	An error has been detected in the headend, which must be investigated.
	Tuner Status	Green – constant	The input module tuners are locked.
		Red	One or more Input module tuners are not locked.
Unit Link 1	Not used		
Unit Link 2	Not used		
Main Unit in multi-unit installation	System Status	Green - constant	Power is on and the headend is operational.
		Green – flashing	The headend is booting up.
		Red	An error has been detected in the headend, which must be investigated.
	Tuner Status	Green – constant	The input module tuners are locked.
		Red	One or more Input module tuners are not locked.
	Unit Link 1	Green – constant	The subunit is connected to the main unit.
		Red	There is a problem with the connection to the subunit.
		No colour	No subunit is connected to the main unit.
Unit Link 2	Green – constant	The subunit is connected to the main unit.	
	Red	There is a problem with the connection to the subunit.	
No colour	No subunit is connected to the main unit.		
Sub Unit 1 in multi-unit installation	System Status	Green – constant	Power is on and the headend is operational.
		Green – flashing	The headend is booting up.
		Red	An error has been detected in the headend, which must be investigated.
	Tuner Status	Green – constant	The input module tuners are locked.
		Red	One or more Input module tuners are not locked.
	Unit Link 1	Green – constant	The subunit is connected to the main unit.
		Red	There is a problem with the connection to the subunit.
		No colour	No subunit is connected to the main unit.
Unit Link 2	Green – constant	The subunit is connected to the main unit.	
	Red	There is a problem with the connection to the subunit.	
No colour	No subunit is connected to the main unit.		

Headend type/usage	LED Name	Colour	Message
Sub Unit 2 in multi-unit installation	System Status	Green – constant	Power is on and the headend is operational.
		Green – flashing	The headend is booting up.
		Red	An error has been detected in the headend, which must be investigated.
	Tuner Status	Green – constant	The input module tuners are locked.
		Red	One or more Input module tuners are not locked.
		Green – constant	The subunit is connected to the main unit.
	Unit Link 1	Red	There is a problem with the connection to the subunit.
		No colour	No subunit is connected to the main unit.
		Green – constant	The subunit is connected to the main unit.
	Unit Link 2	Red	There is a problem with the connection to the subunit.
		No colour	No subunit is connected to the main unit.
		Green – constant	The subunit is connected to the main unit.

Service tool - System requirements

The headend needs to be configured before it can be used.

Computer minimum requirements

A computer meeting the following minimum requirements is required for configuring the headend.

Operating system:	Windows XP or later	
Browser:	Mozilla firefox	ver. 46.0.1 or newer
	Google Chrome	ver. 50.0.2661 or newer
	MS internet explorer 11	ver. 11.0.9600.18314 or newer

Static IP address

A static address must be used on the computer you use to configure the headend. Refer to the computer's operating software documentation for assistance on using static IP addresses.

Physical connection to headend

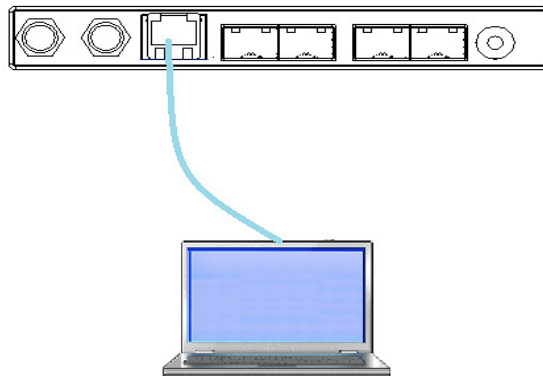

Connect a Cat5e shielded cable or better between the computer's network port and the configuration port on the headend.

Starting service tool

1. Open a web browser window.
2. Enter 'http://192.168.0.100' in the web address field.
3. Press **Enter**.

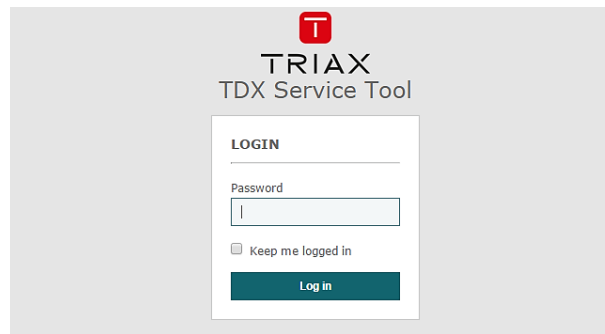

4. Enter the password.
5. Press the **Log in** button.

Note:

Password = 'triaux1234' when the service tool is opened on each headend for the first time.

The **Keep me logged in** checkbox overrides the system's automatic time out function, which is activated after 20 minute's inactivity.

Overview

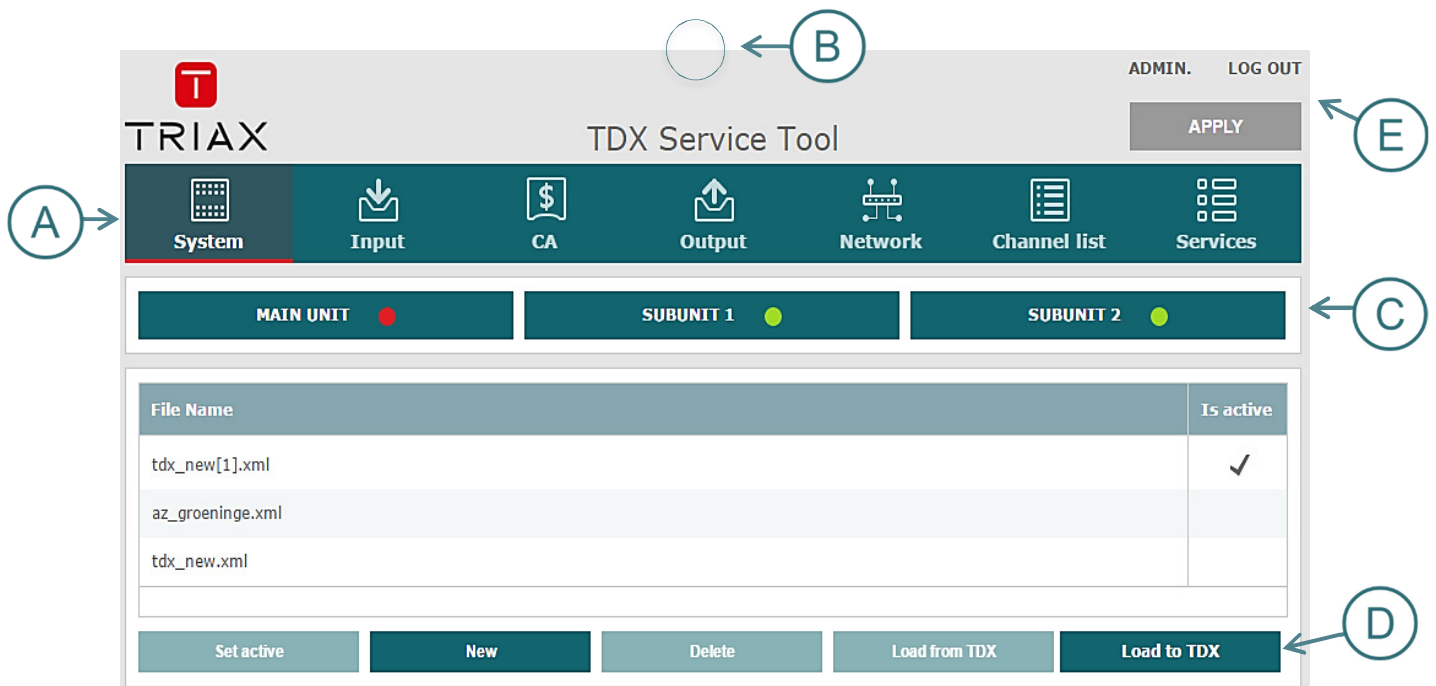

Tabs A

Accesses the various tabs used to configure the headend's input and output modules.

System	The service tool's 'home' window. Provides system overview information and configuration activation/control.
Input	Tab for configuring input modules and services.
CA Modules	Tab for configuring CI modules and CA cards. Refer to output module manuals for information.
Output Network	Tab for configuring output modules and services.
Channel List	Tab for viewing available channels, refer to input module manuals for information.
Services	Tab for service overview with filter options

Communication circle B

Indicates whether the service tool is communicating with the headend unit.

Circle is spinning | The service tool and headend are communicating.

System icons C

Indicates whether the headend unit is functioning correctly.

Green	The headend unit is functioning correctly.
Red	The headend unit is NOT functioning correctly. To get further information: press relevant button : <ul style="list-style-type: none"> • Main unit • Subunit 1 • Subunit 2

Misc. buttons E

Apply	Stores and applies the configuration settings.
Log In/Out	Service tool access control.
Admin	Opens the settings for service tool window, where language, location, time zone, and initial IP addresses are specified.

Configuration buttons D

Set active	Set the selected configuration active
New	Create a new default configuration
Delete	Delete the selected configuration
Load from TDX	Load new configuration from computer
Load to TDX	Load selected configuration to computer

NOTE:
Press checkmark to select configuration.

The system language, locale, and time zone need to be specified on each headend unit. It is also necessary to specify IP addresses for headends which are located on a distribution network.

Language

1. Press the **Admin** button at the top right-hand corner of the System window.
2. Open the **Current language** drop-down list.
3. Select the desired language.
4. Press the **UPDATE** button, down below.

SETTINGS FOR TDX SERVICE TOOL

Language settings

Change language for TDX Service Tool

Current language

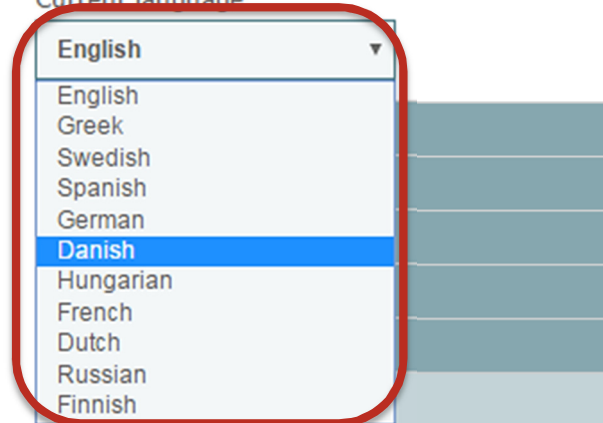

Location

1. Press the **Admin** button at the top right-hand corner of the System window.
2. Expand the **Country settings** area.
3. Open the **Current location** drop-down list.
4. Select the country where the headend is located.
5. Press the **UPDATE** button, down below.

SETTINGS FOR TDX SERVICE TOOL

Country settings

Change location for the TDX installation

Current location

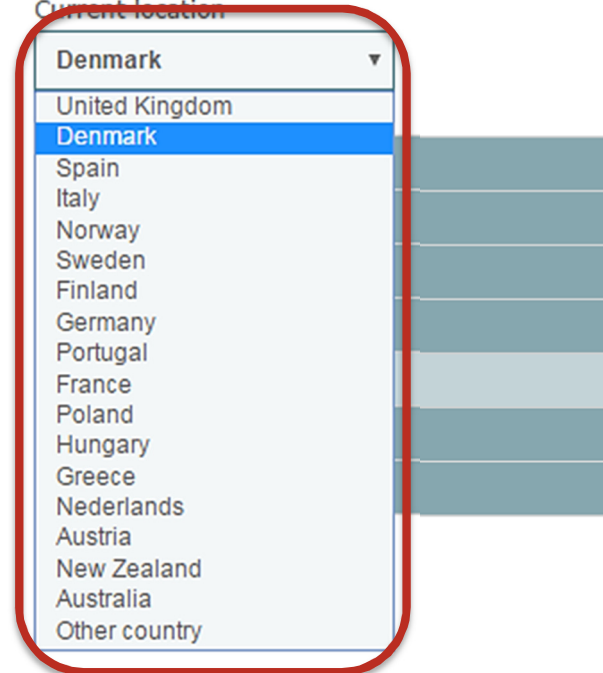

1. Press the **Admin** button at the top right-hand corner of the **System** window.
2. Expand the **Time zone settings** area.
3. Open the **Input module (Main unit)** drop-down list.
4. Select the input module that is to be used for setting the headend's system date/time/time zone.
5. Press the **UPDATE** button, down below.

Time set by NTP server

It is possible to have the time in the TDX set by a NTP server.

The *Primary* and *Secondary time server* can be setup using either a. IP address like "192.168.30.31" or a URL like "the.best.ntpservers.org". If a URL is used then a DNS must be setup in the *IP settings* sub menu. See below.

SETTINGS FOR TDX SERVICE TOOL

- > Language settings
- > Country settings
- > Time settings
- > Password settings
- > License handling
- ▼ IP settings

Configuration port

IP address	Subnet mask	Default gateway
192.168.0.100	255.255.255.0	192.168.0.1

DNS Server 1	DNS Server 2
8.8.8.8	

Edit link IP settings for system

ENTER SETUP

The TDX uses 512 IP addresses for internal use, specify first address

Start	End
239.192.0.0	239.192.1.255

SETTINGS FOR TDX SERVICE TOOL

- > Language settings
- > Country settings
- ▼ Time settings

Select input module from main unit to use as source for system time. If r

Input module (Main unit)

1 DVB-T

Enable NTP timeserver

Enter IP address or host name for time servers

Primary time server Secondary time server

SETTINGS FOR TDX SERVICE TOOL

- > Language settings
- > Country settings
- ▼ Time settings

Select input module from main unit to use as source for system time. If r

Input module (Main unit)

1 DVB-T

Enable NTP timeserver

Enter IP address or host name for time servers

Primary time server Secondary time server

Security

1. Press the **Admin** button at the top right-hand corner of the System window.
2. Expand the **Password settings** area.
3. Specify the current password in the **Old password** field. ('**triax1234**') if the service tool is being used for the first time.
4. Specify a new password in the **New password** field.
5. Re-specify the new password in the **Confirm password** field.
6. Press the **UPDATE** button, down below.

SETTINGS FOR TDX SERVICE TOOL

- > Language settings
- > Country settings
- > Time settings
- ▼ Password settings

Change password for TDX system

Old password New password Confirm password

Features and License Keys

Licenses handle the Features (e.g. IP input and/or IP output or SNMP functionality) available for the Headend. To activate a specific Feature, you need to type in the License Key for the specific Feature. The License Key and matching Unique ID is created for the individual Headend, and can therefore not be re-used in other Headend installations.

When you have purchased and retrieved the necessary License Keys and Unique IDs they need to be entered into the Headend system to activate the Feature:

1. Press the Admin button at the top right-hand corner of the system window.
2. Expand the "License handling" area.
3. Enter the retrieved License Keys to the matching Unique IDs in the order given from TRIAX.
4. Press the ACTIVATE button, and the installed license is listed.

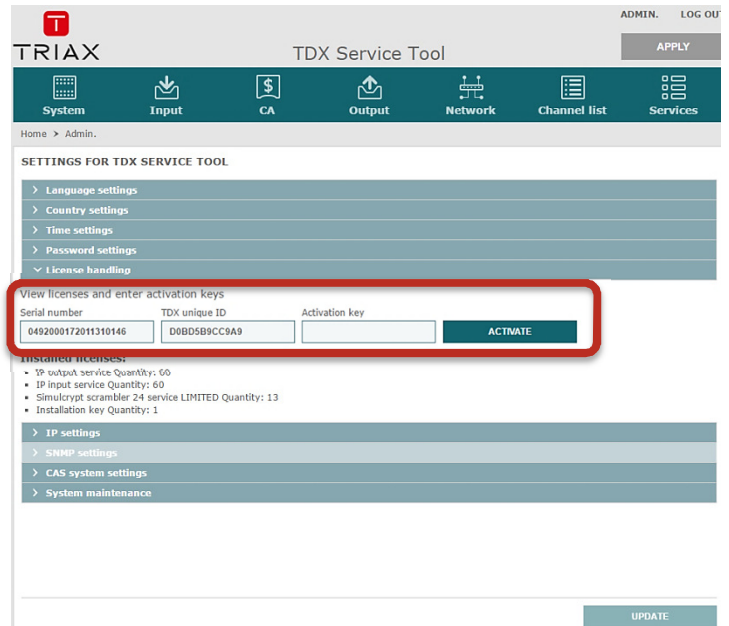

How-To get License Keys

To retrieve a License Key, you need to access the TRIAX Product Registration Tool (PRT) on our online HELPDESK: <http://www.triax.com/Helpdesk/ProductRegistrationTool>

NOTE:

Access to TRIAX HELPDESK require personal login credentials! If not already acquired, please apply online on <http://www.triax.com/Service/UserSubscriptionSLA>

To register a Headend system and retrieve new License Keys, you will need to upload the Equipment-File for the specific Headend. The Equipment-File is automatically generated by the service tool:

1. Press the Admin button at the top right-hand corner of the system window.
2. Expand the "System maintenance" handling area.
3. Press SAVE EQUIP. and the Equipment-File is generated and saved on your PC.

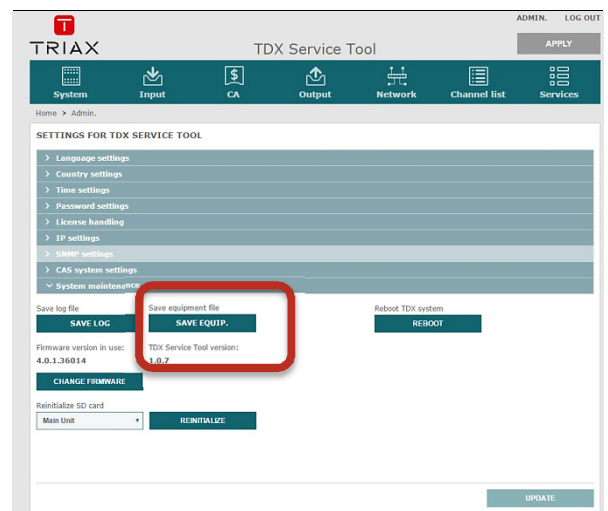

30-day Trial Period, Free of charge access to all Features

The TDX Black Edition is delivered with a free of charge 30-day installation period with unlimited access to all available Features. When TDX Black Edition is initialized for the first time, you have to start the 30-day Trial Period. The START TRIAL box is automatically displayed, and you start the trial by pressing START. Above the menu bar you will now see the remaining days of your trial period.

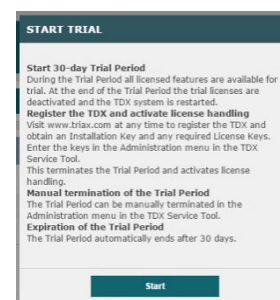

Attention

When trial period reaches 0 days, the Headend will automatically restart and no Features will be available..

To activate Features permanently, please follow procedure described in "Features and License Keys"

To end 30-day Trial Period actively you have 2 choices:

1. Retrieve "Installation Key" license from PRT. At the same time please retrieve License Keys for any other Features to be permanently installed in the Headend.
2. Expand "License handling" area and press END TRIAL.

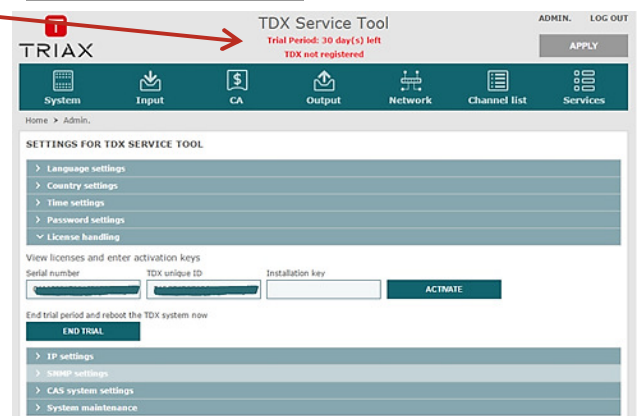

IP settings

It may be necessary to specify specific IP addresses for the headend to avoid network IP address conflicts.

Note: Headend IP addresses can be reset to factory default settings if required. This is done via the ID switch located on the headend unit(s).

1. Press the **Admin** button at the top right-hand corner of the System window.
2. Expand the **IP settings** area.
3. Specify the headend's IP address, subnet mask and default gateway in the corresponding fields.
4. Press the **UPDATE** button, down below.

SETTINGS FOR TDX SERVICE TOOL

> Language settings
> Country settings
> Time settings
> Password settings
> License handling
▼ IP settings

Configuration port

IP address	Subnet mask	Default gateway
192.168.0.100	255.255.255.0	192.168.0.1

DNS Server 1	DNS Server 2
8.8.8.8	

Edit link IP settings for system

ENTER SETUP

The TDX uses 512 IP addresses for internal use, specify first address

Start	End
239.192.0.0	239.192.1.255

IP settings - continued

This step is only relevant where Main and sub units are connected to the network via a Gigabit network switch.

1. Press the **ENTER SETUP** button

The **IP Settings** window is used to specify unique IP addresses and subnet masks used by the Link 1 and Link 2 sockets on the main and sub units. This provides additional functionality to avoid IP address conflicts.

1. Select the **Switch** radio button.
2. Specify unique IP addresses and subnet mask details for the main and subunits in the corresponding fields.
3. Press the **UPDATE** button, down below.

IP SETTINGS ✕

Connection type: Switch Direct

Main unit		
Link	IP address	Subnet mask
Link 1	192.168.1.3	255.255.255.0
Link 2	192.168.2.3	255.255.255.0
AUX 1	192.168.5.5	255.255.255.0
AUX 2	192.168.6.6	255.255.255.0

Sub unit 1		
Link	IP address	Subnet mask
Link 1	192.168.1.1	255.255.255.0
Link 2	192.168.3.1	255.255.255.0
AUX 1	192.168.4.4	255.255.255.0
AUX 2	192.168.5.5	255.255.255.0

Sub unit 2		
Link	IP address	Subnet mask
Link 1	192.168.2.2	255.255.255.0
Link 2	192.168.3.2	255.255.255.0
AUX 1		
AUX 2		

Cancel **OK**

NOTE:

The **AUX 1**, **AUX 2** and associated **IP Address** and **Subnet mask** fields are used in connection with the IP output module.

IP settings - continued

Remaining steps are valid for all multi-unit installations.

The 512 IP addresses used by the headend(s) must not conflict with any of the IP addresses used either within the network or for services.

1. Enter the first of the 512 IP addresses used for internal purposes in the **Start** field.
2. Press the **UPDATE** button, down below.

A message is displayed if the headend needs to be rebooted due to IP address changes having been made.

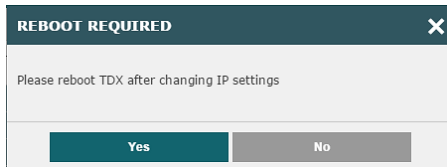

SNMP settings

SNMP stands for "Simple Network Management Protocol".

SNMP is an Internet standard protocol that you use for exchanging management information between the equipment in a CATV network. You can use SNMP to monitor sub-headends, fibre nodes and amplifiers or to check the status of the equipment.

1. Press the **Admin** button at the top right-hand corner of the System window.
2. Expand the **SNMP settings** area.
3. Specify the IP address of the computer that monitors the network, i.e. the SNMP manager.
4. Specify new SNMP port numbers if you want to change the default values in the two SNMP port fields.
5. Enter a password to access the SNMP manager in the **Community string** field.
6. Press the **UPDATE** button, down below.

For an overview of SNMP traps, see "SNMP Traps".

SETTINGS FOR TDX SERVICE TOOL

- > Language settings
- > Country settings
- > Time settings
- > Password settings
- > License handling
- > IP settings

Configuration port

IP address	Subnet mask	Default gateway
192.168.0.100	255.255.255.0	192.168.0.1

DNS Server 1	DNS Server 2
8.8.8.8	

Edit link IP settings for system

ENTER SETUP

The TDX uses 512 IP addresses for internal use, specify first address

Start	End
239.192.0.0	239.192.1.255

SETTINGS FOR TDX SERVICE TOOL

- > Language settings
- > Country settings
- > Time settings
- > Password settings
- > License handling
- > IP settings
- > SNMP settings

Connection settings for SNMP server

Manager IP	SNMP port	SNMP port (Traps)	Community string
0.0.0.0	161	162	TDX

CAS server settings

- Enter relevant information – as example shown here.
- Press the **UPDATE** button, down below.

NOTE:
CAS system should be connected to the TDX system. TDX should have quality input signal and user should have a license.

SETTINGS FOR TDX SERVICE TOOL

- > Language settings
- > Country settings
- > Time settings
- > Password settings
- > License handling
- > IP settings
- > SNMP settings
- > CAS system settings

CAS system 1

CAS system name
Panaccess CAS 1

CAS system ID (hex value)	EMM server port	ECM server IP address	ECM server IP port
0x4afc	5000	10.50.3.216	12500

Rebooting

1. Press the **Admin** button at the top of the right-hand corner of the System window.
2. Expand the System maintenance area.
3. Press the **Reboot** button.
4. You will be prompted before reboot takes place.

NOTE:
Changes to IP addresses only take effect when the headend has been rebooted.

SETTINGS FOR TDX SERVICE TOOL

- > Language settings
- > Country settings
- > Time settings
- > Password settings
- > License handling
- > IP settings
- > SNMP settings
- > CAS system settings
- > System maintenance

Save log file SAVE LOG	Save equipment file SAVE EQUIP.
Firmware version in use: 4.0.1.35819	
TDX Service Tool version: 1.0.4	
CHANGE FIRMWARE	
Reinitialize SD card Main Unit	REINITIALIZE

Reboot TDX system
REBOOT

View system log

It is possible to save log files for viewing headend actions.

1. In the System maintenance – press **SAVE LOG**

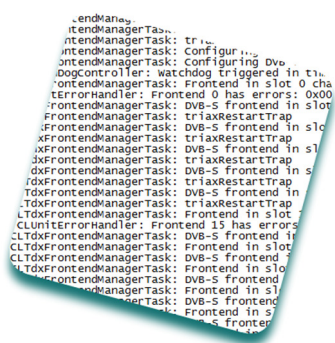

2. A txt file is saved to the Downloads folder in Windows – see snippet above.
3. Open the TDXLOG.txt file in ie. Notepad or the like.
4. Rename the file if needed

SETTINGS FOR TDX SERVICE TOOL

- > Language settings
- > Country settings
- > Time settings
- > Password settings
- > License handling
- > IP settings
- > SNMP settings
- > CAS system settings
- > System maintenance

Save log file SAVE LOG	Save equipment file SAVE EQUIP.
Firmware version in use: 4.0.1.35819	
TDX Service Tool version: 1.0.4	
CHANGE FIRMWARE	
Reinitialize SD card Main Unit	REINITIALIZE

Reboot TDX system
REBOOT

Firmware updating

Firmware updates are available from the support/helpdesk sites at [TRIAX](#). Always read the release notes to determine whether the headend would benefit from available firmware updates or not.

1. Press the CHANGE FIRMWARE button
2. A dialog box that lists the current and previous F/W versions, will open:

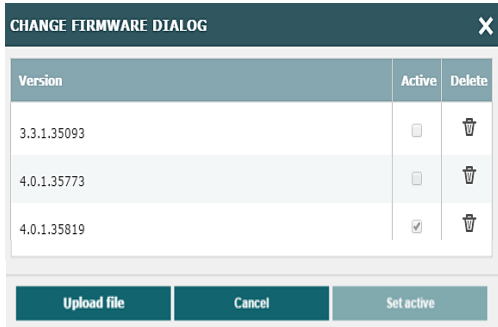

3. To change the F/W, highlight the firmware you want to install, press SET ACTIVE or Press the UPLOAD FILE button, find the desired F/W to be uploaded and installed, and then press SET ACTIVE
4. When you have pressed the the SET ACTIVE button a box opens, where you have 2 options:
 - a. REPLACE ALL
updates all of the headend's firmware, i.e. modules, system controller and user interface. **(This is recommended)**
 - b. UPDATE OLD PACKAGES
Updates only outdated modules
5. Press START UPDATE, and the update starts, during which you have can abort if needed.
6. When update is finished (could take some time) you will be noticed.

SETTINGS FOR TDX SERVICE TOOL

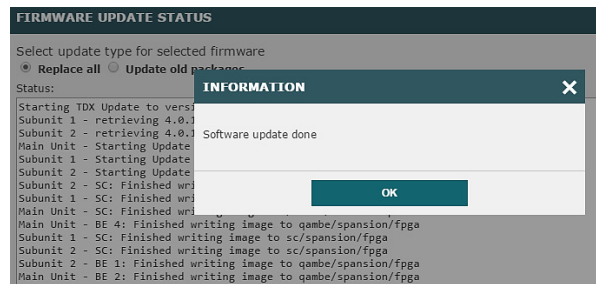
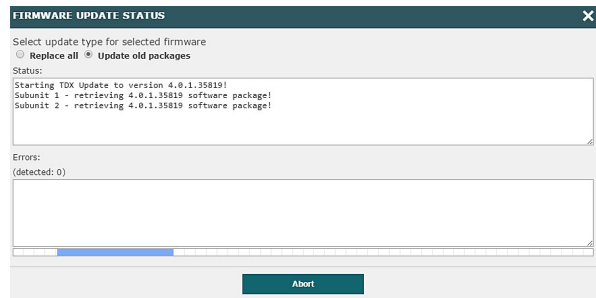
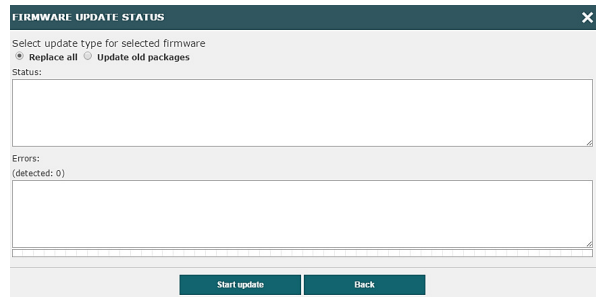
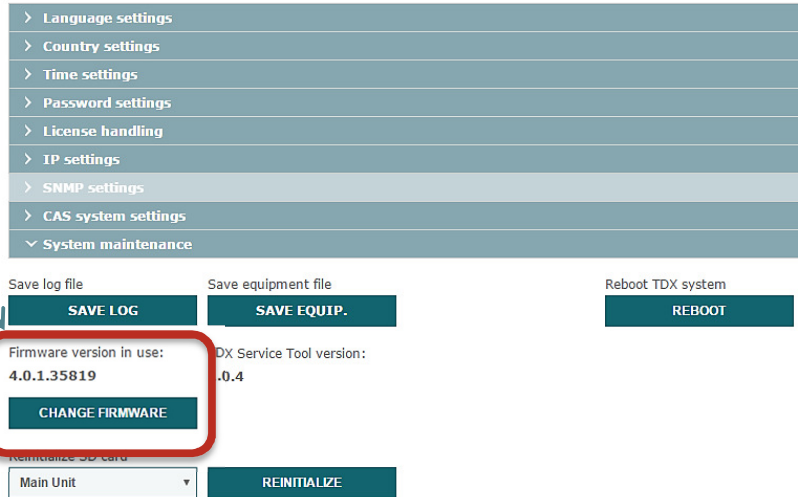

NOTE:
Service distribution to end-users will be disrupted while the headend restarts.

The **Update old packages** radio button should only be used in cases where the headend consists mainly of new modules, but also contains some older modules that might benefit from an update.

S/W NOTE:
As from the F/W version 4.0.1 it is not possible to reverse to older Firmware. This is due to significantly changed and improved firmware.

Firmware clean up

Select the firmware updates to be removed from the system tool by pressing the DELETE bucket, and confirm with YES



Format file system in flash

If data in the TDX needs to be deleted, then you need to format file system in flash of the TDX.

Be aware: this operation DELETES ALL data in the TDX – including License data !

1. Set rotary wheel to 6
2. Reboot TDX
3. Wait for the 4 front LED's to blink red
4. Set wheel to 2
5. The 2nd diode should slowly blink green followed by rapid blinking green after some seconds
6. Wait for diode to turn solid green
7. Set wheel back to original position
8. Reboot

Force TDX systemcontroller in failsafe mode

If there is a S/W version mismatch inside the TDX system – then the system will go into "Failsafe" mode. To get back into normal mode, a S/W update has to be performed.

The Failsafe mode can also be forced – see description below:

1. Set rotary wheel to 6
2. Reboot TDX
3. Wait for the 4 front LED's to blink red
4. Set wheel to 1
5. The 1 st diode should slowly blink followed by fast blinking green
6. Wait for diode to turn solid green
7. Set wheel back to original position
8. Reboot

Reinitialize SD card

If the TDX system reports "SD card corrupt" then the SD card needs to be reinitialized.

This can happen for the SD card in either the Main or Subunit 1 or 2. (if your TDX system got Subunits)

Be aware: This function deletes ALL information stored in the SD card.

The SD card stores NON critical data, (ie. logfiles and S/W update packages).

Choose the unit in which the SD card needs to be reinitialized.

SETTINGS FOR TDX SERVICE TOOL

- > Language settings
- > Country settings
- > Time settings
- > Password settings
- > License handling
- > IP settings
- > SNMP settings
- > CAS system settings
- > System maintenance

Save log file

SAVE LOG

Save equipment file

SAVE EQUIP.

Reboot TDX system

REBOOT

Firmware version in use:

4.0.1.35907

TDX Service Tool version:

1.0.6

CHANGE FIRMWARE

Reinitialize SD card

Main Unit

REINITIALIZE

IP out service list

It is possible to get the list of services at IP out in the following formats:

- XSPF
- M3U
- Extended M3U
- Extended++ M3U

XSPF can be accessed by enter "/ipoutservices" after the URL for the TDX configuration.

Sample:

```
<?xml version="1.0" encoding="UTF-8"?>
<playlist version="1" xmlns="http://xspf.org/ns/0/">
<trackList>
<track><title>DR1</title><location>udp://@239.194.0.1:50172</location>
<extension
application="http://www.triax.com"><poolserviceid>4</poolserviceid></extension></track>
<track><title>Syd</title><location>udp://@239.194.0.2:50172</location>
<extension
application="http://www.triax.com"><poolserviceid>6</poolserviceid></extension></track>
</trackList>
</playlist>
```

M3U can be accessed by enter "/orgChanlist.m3u" after the URL for the TDX configuration.

This service list contains

- IP addresses and port numbers

Sample:

```
udp://239.194.0.1:50172
udp://239.194.0.2:50172
```

Extended M3U can be accessed by enter "/chanlist.m3u" after the URL for the TDX configuration.

The service list is compliant to SAT>IP Protocol Specification (ver. 1.2.2) and is defined as "extended M3U channel list" In the standard under appendix A2.1

This service list contains

- IP address and port number
- Service name
- LCN

Sample:

```
#EXTM3U
#EXTINF:0,1, DR1
udp://239.194.0.1:50172
#EXTINF:0,3, Syd
udp://239.194.0.2:50172
```

Extended++ M3U can be accessed by enter "/satip.m3u" after the URL for the TDX configuration.

The service list is based at the Extended M3U with further extensions.

The service list can be used for TV sets. Panasonic is one TV set vendor that supports this service list as service discovery.

The list is used for communication between the TDX system controller and the TDX EPG server.

This service list contains

- IP address and port number
- Service name, transport stream ID, original network ID
- LCN
- Service type (1=TV, 2=Radio)

Sample:

```
#EXTM3U
#EXTINF:0,1, DR1
udp://239.194.0.1:50172?stype=1&onid=43962&tsid=0&svcid=4
#EXTINF:0,3, Syd
udp://239.194.0.2:50172?stype=1&onid=43962&tsid=0&svcid=6
```

All above list will be downloaded:

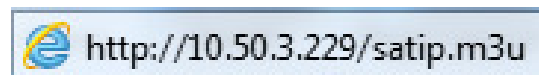
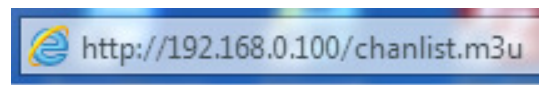
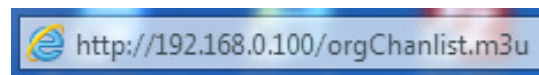

System information

Viewing system information

Detailed information is available on headend units:

1. Select the **System** tab.
2. Select the main unit or one of the subunits in the **System information list** area.

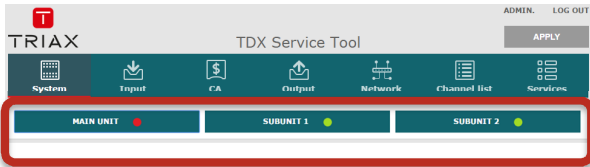

The **System information for unit** window is displayed. The window contains information relating to:

Any headend system errors

Name and associated software version of input and output modules

Note that the software versions installed on all headends, including each input/output module must be identical.

Update the software for the entire headend installation (including input/output modules) if this is not the case.

- MAC addresses
- Current/minimum/maximum temperatures
- Power supply

SYSTEM INFORMATION FOR UNIT	
Show detailed system information for selected unit	
Name	Value
System errors (8 items)	
System error	Error on master unit
Unit error	Error on input module
Unit error	Error on output module
Unit error	Error on common interface-module
Input module 2 error	Missing input
Input module 3 error	Missing input
Input module 4 error	Missing input
Input module 8 error	Missing input
Software versions (21 items)	
Unit SW Version	4.0.1.35907
Input #1 SW Version	3.1.1.31736
Input #2 SW Version	3.1.1.31736
Input #3 SW Version	3.1.1.31736
Input #4 SW Version	3.1.1.31736
Input #5 SW Version	3.1.1.31736
Input #6 SW Version	3.1.1.31736
Input #7 SW Version	3.1.1.31736
Input #8 SW Version	3.1.1.31736

Duplicated PID's

Selecting IP services for output may result in a selection of services from an MPTS stream that uses the same PID for two or more services.

It is not possible to output services with identical PIDs. If you have selected services with identical PIDs, the System icon of the headend unit that handles the output of the services with identical PIDs turns red.

- Click the affected unit to open the **System information for unit** window.

The **System information for unit window** lists the output module(s) and channel(s) which attempt to output services with identical PIDs.

To solve the problem you have to open the configuration window of the output module(s) listed in the **System information for unit** window, and deselect the selected IP services one by one while checking the **System information for unit** window until the message disappears from the window.

SYSTEM INFORMATION FOR UNIT	
Show detailed system information for selected unit	
Name	Value
System errors (1 item)	
Unit error	Duplicate PID routes detected
Software versions (6 items)	
Unit SW Version	4.0.1.36348
Input #1 SW Version	3.1.1.31736
Input #3 SW Version	3.1.1.31736
Input #5 SW Version	3.1.1.31736
Output #2 SW Version	4.0.1.36348
Output #6 SW Version	4.0.1.36348
MAC addresses (3 items)	
MAC Config port	00:50:C2:B2:50:0C
MAC Link1	00:50:C2:B2:50:0D
MAC Link2	00:50:C2:B2:50:0E

Managing configuration files

Creating

1. Select the **System** window.
2. Select the **New** button.

An empty configuration file is created and listed in the configuration list area.

Activating

1. Select the **System** tab.
2. Select the configuration that is to be actively used on the headend.

Press the **Set active** button.

Deleting

1. Select the **System** tab.
2. Highlight the configuration file to be deleted.
Press the **Delete** button.

Saving

Headend configuration files can, if desired, be saved on the computer. This simplifies the process of configuring additional headends that contain the same modules.

A saved configuration file can also be used on headends that do not contain exactly the same modules. It will, however, be necessary to reconfigure/delete/add the modules that differ between the initial headend and that being configured.

1. Select the **System** tab.
2. Press the **Load from TDX** button.

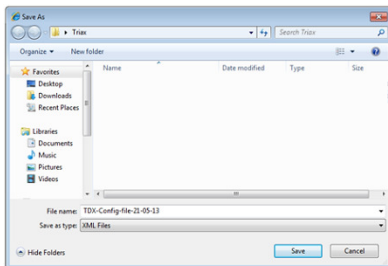

3. Navigate to where the configuration file is to be saved.
4. Enter a name for the configuration file.
5. Select 'XML' in the **File type** field.
6. Press the **Save** button to save.

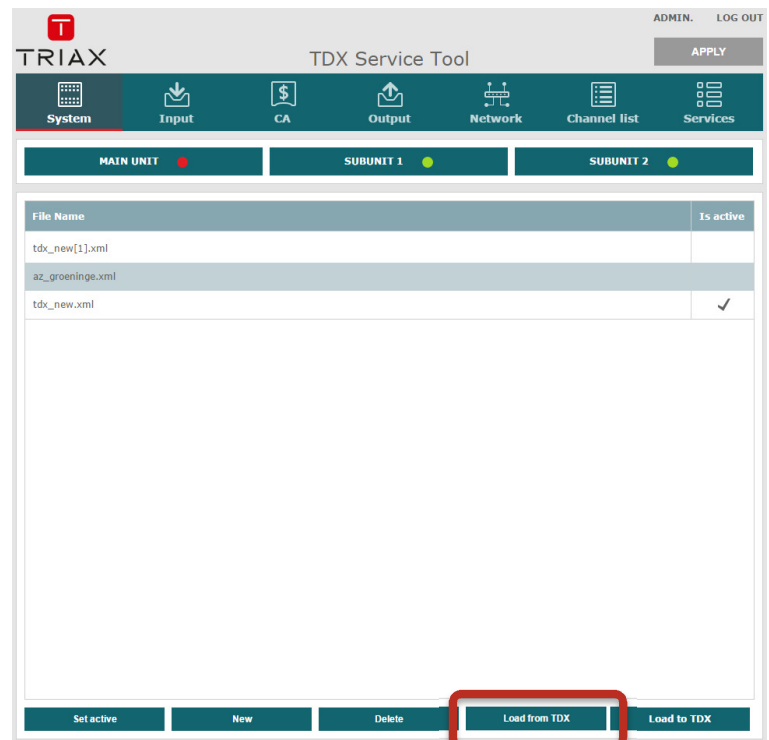

Uploading

Configuration files previously saved on a computer can be transferred to the system tool to simplify the configuration process.

Any module differences will need to be manually configured.

1. Select the **System** tab.
2. Press the **Load to TDX** button.

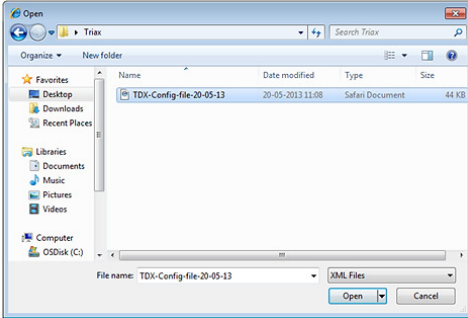

3. Navigate to the folder where the configuration file to be uploaded is located.
4. Select the file.
5. Press the **Open** button.

The configuration file will now be listed in the configuration list area. A number in brackets, e.g. (1), is added to the name of the new file if an identically named configuration file is already present.

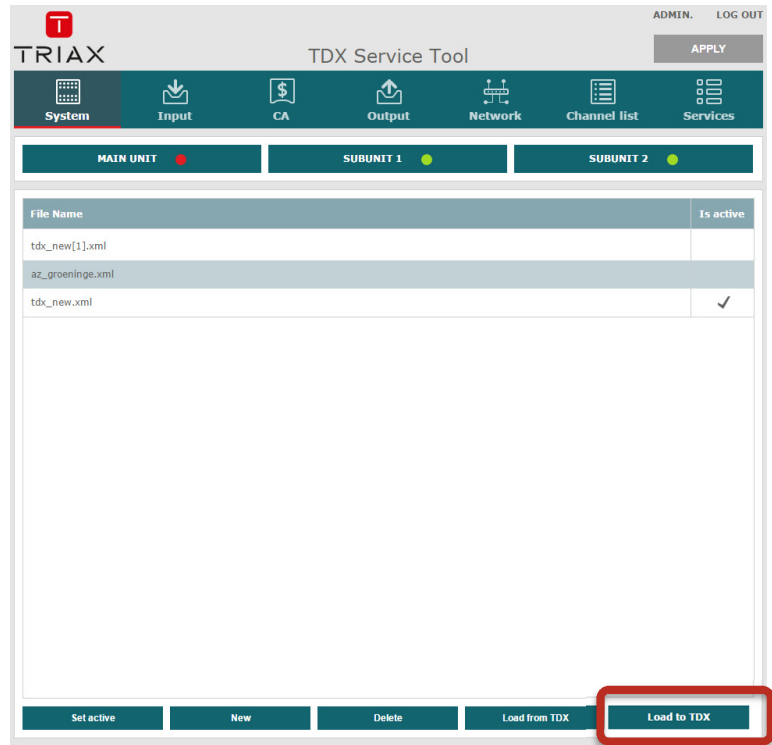

IP Input configurations

The headend system includes basic IPTV functionality which enables service delivery over a packet-switched network infrastructure. To handle IP input through the Link sockets the following requirements must be satisfied:

- IP multicast streaming (UDP streaming)
- Possibility of RTP
- Possibility of IGMP version 2
- SPTS or MPTS including PAT, PMT, CAT

Important:

The TDX headend system supports up to 7 TS packets per IP packet at IP inputs.

The TDX headend system does not support IP fragmentation at IP inputs, which may occur if the IP packets are transmitted over a network with a Maximum Transmission Unit (MTU) less than approximately $80 + N \times 188$ bytes, where N is the number of packets per IP packet..

Recommended settings are 7 TS packets per IP packet and a minimum MTU of 1500 bytes in the entire network path.

NOTE:

Licenses for IP input are required to be able to use the IPTV functionality in the headend. The licenses can be purchased from Triax Sales, and need to be activated, see "Activating licenses".

Creating

1. Select the **Input** tab.
2. Select the **IP inputs** sub-tab.
3. Press the **Setup** button for the link socket that processes IP input.
4. Specify the desired IP address and associated IP port number in the corresponding fields.
5. Press the **Update** button.
6. Check the **Selected services** checkbox for one or more services to select the service(s) you want to use.

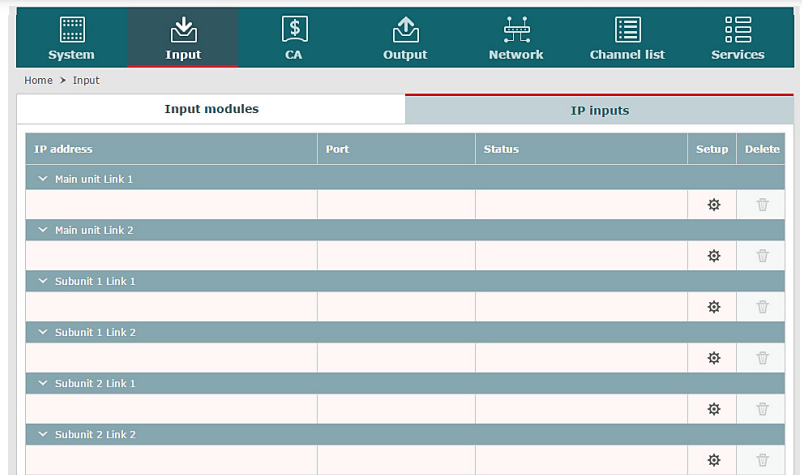

The screenshot shows the 'Input' tab with the 'IP inputs' sub-tab selected. A table lists various link sockets under 'Input modules' and 'IP inputs'. Each row includes columns for 'IP address', 'Port', 'Status', 'Setup', and 'Delete'. The 'Setup' column contains a gear icon for each entry.

IP address	Port	Status	Setup	Delete
Main unit Link 1			⚙️	🗑️
Main unit Link 2			⚙️	🗑️
Subunit 1 Link 1			⚙️	🗑️
Subunit 1 Link 2			⚙️	🗑️
Subunit 2 Link 1			⚙️	🗑️
Subunit 2 Link 2			⚙️	🗑️

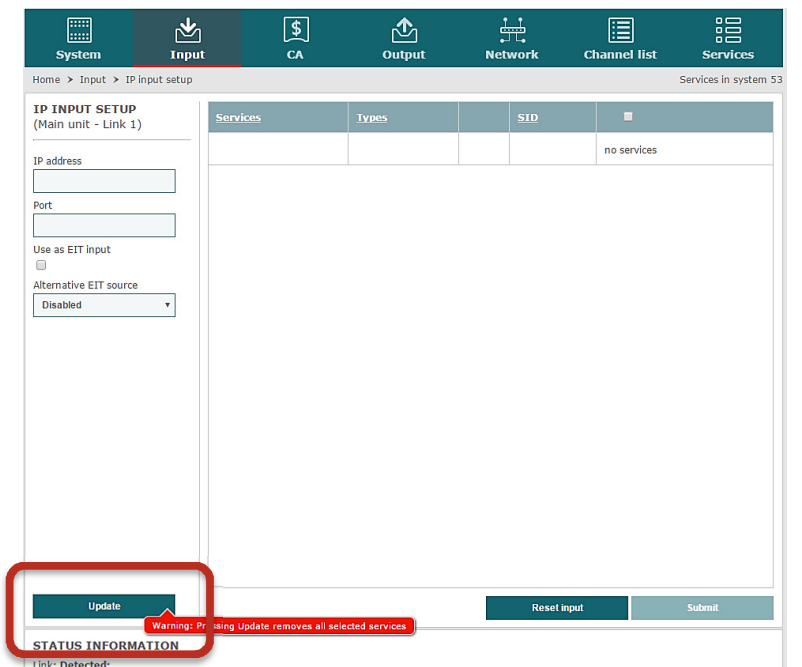

The screenshot shows the 'IP INPUT SETUP' page for 'Main unit - Link 1'. It includes input fields for 'IP address' and 'Port', a 'Use as EIT input' checkbox, and an 'Alternative EIT source' dropdown menu. A 'Services' table is shown with columns for 'Services', 'Types', and 'SID', currently displaying 'no services'. At the bottom, there are 'Update', 'Reset input', and 'Submit' buttons. A red box highlights the 'Update' button, with a warning message: 'Warning: Pressing Update removes all selected services'. Below the buttons is a 'STATUS INFORMATION' section showing 'Link: Detected;'. The top navigation bar includes 'System', 'Input', 'CA', 'Output', 'Network', 'Channel list', and 'Services' tabs.

Creating - continued

Important:

If the IP input uses MPTS streams, then each stream can contain one or more services. An MPTS stream may use the same PID (Package ID) for two or more of the services that it contains.

However, the headend system cannot output services with the same PID. To discover services with the same PID is NOT possible until you have selected the services with identical PIDs in order to output them using an output module or a Link socket.

If you attempt to output services with identical PIDs:

- the System Status LED turns red on the unit that tries to output the IP services,
- the System icon of the affected headend unit turns red on the System tab in the Service Tool,
- the System Status LED and System icon turn red on the main unit in a multi-unit installation.
- See "Duplicated PIDs" for further information.

7. View the **Status information** area to ensure that IP data is being sourced through the Link socket.
8. Press the **Submit** button.

The selected service is now available in the headend service pool.

9. Press the Apply button to save the new settings in the configuration.

Input modules		IP inputs			
IP address	Port	Status	Setup	Delete	
Main unit Link 1					
239.0.0.1	1234		⚙️	🗑️	
Main unit Link 2					
			⚙️	🗑️	
Subunit 1 Link 1					
			⚙️	🗑️	
Subunit 1 Link 2					
			⚙️	🗑️	
Subunit 2 Link 1					
			⚙️	🗑️	
Subunit 2 Link 2					
			⚙️	🗑️	

Specifying EIT/EPG source

One input on each link per headend can be configured to carry Event Information Table (EIT) data.

1. Specify the desired IP address and associated IP port number in the corresponding fields.
2. Check the **Use as EIT input** checkbox.
3. Press the **Update** button.
4. Check the **Selected services** checkbox for one or more services to select the service(s) you want to use
5. View the **Status information** area to ensure that IP data is being sourced through the Link socket.
6. Press the **Submit** button.

Home > Input > IP input setup Services in system 53

Services	Types	SID	
no services			

IP INPUT SETUP
 (Main unit - Link 1)

IP address:
 Port:
 Use as EIT input:
 Alternative EIT source:

Warning: Pressing Update removes all selected services

1. Specify the desired **IP address** and associated **IP port number** in the corresponding fields.
2. Open the **Alternative EIT source** drop-down list.
3. Select the **EIT source** to be used.
4. Press the **Update** button.
5. Check the **Selected services** checkbox for one or more services to select the service(s) you want to use
6. View the **Status information** area to ensure that IP data is being sourced through Link 1 or 2 on the socket.
7. Press the **Submit** button.

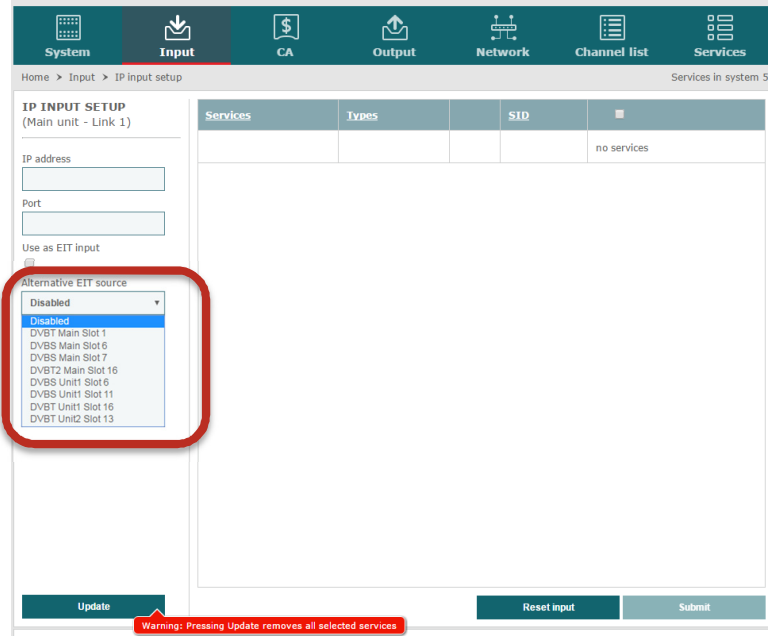

EIT for Viasat services

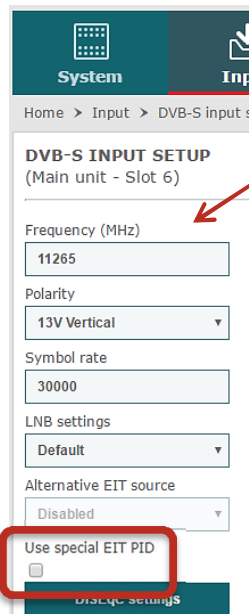

It is possible to change the EIT at PID 57 received at DVB-S input and convert the EIT to the standard PID (PID 18) for EIT. This function is for Viasat services. To activate this function select *Use special EIT PID* at the *Input* menu for DVB-S.

Modifying

To modify an existing IP input configuration:
 -Press the **Setup** button associated with the IP input configuration.
 -Make the required modifications as when creating an IP input configuration.
 -Press the **Submit** button.
 -Press the **Apply** button when the modifications have been made.

Slot	HW installed	Frequency	Network ID/TS ID	Status	Setup	Delete	Log
Main unit (16 items)							
1	DVB-T	546000 KHz	8400	Locked	⚙️	🗑️	📄
2	DVB-S	10744 MHz (H)	N/A	No signal	⚙️	🗑️	📄
3	DVB-S	11362 MHz	N/A	No signal	⚙️	🗑️	📄
4	DVB-S	11494 MHz	N/A	No signal	⚙️	🗑️	📄
5	DVB-T input configured as NONE	0 KHz	N/A	Not configured	⚙️	🗑️	📄
6	DVB-S	11265 MHz (V)	33	Locked	⚙️	🗑️	📄
7	DVB-S	11305 MHz	32	Locked	⚙️	🗑️	📄
8	DVB-S	11345 MHz	N/A	No signal	⚙️	🗑️	📄
9	DVB-T input configured as NONE	0 KHz	N/A	Not configured	⚙️	🗑️	📄
10	DVB-S input configured as NONE	0 KHz	N/A	Not configured	⚙️	🗑️	📄
11	DVB-S input configured as NONE	0 KHz	N/A	Not configured	⚙️	🗑️	📄

Deleting

1. Press the **Delete** button of the IP input to be removed.
2. Confirm that the selected IP input is to be removed.
3. Press the **Apply** button.



IP output configurations

Creating

The headend system offers the following possibilities when you output IPTV services through the Link sockets.

- IP multicast streaming (UDP streaming)
- No RTP option
- IGMP version 2
- SPTS or MPTS including SDT, PAT, PMT, CAT
- Packet ratio of 1 TS packet per IP packet
- Not possible to change service ID (SID)

NOTE:

Licenses for IP output are required to be able to use the IPTV functionality in the headend. The licenses can be purchased from Triax Sales, and need to be activated, see "Activating licenses".

1. Select the **Output** tab.
2. Select the **IP outputs** sub-tab.
3. Press the **Setup** button for the link socket that will process IP output.
4. Specify the desired **IP address** and associated **IP port number** in the corresponding fields.
5. Press the **Services** button.

The **Select Services** window displays services from input that has entered the headend system through the same unit which contains the Link socket(s) being used for service distribution.

6. Select the services to be distributed through the link.
7. Press the **UPDATE** button, down below.

Notes:

Services selected for one output on a Link will not be selectable for other outputs on the same Link. Re-scrambled and/or descrambled services cannot be distributed using the Link sockets. They can, however, be distributed using an IP output module and the AUX sockets. The IP output module offers the possibility to solve these limitations:

- RTP
- Set packet ratio for TS packets per IP packet
- Changing service ID (SID)
- Selection of descrambled service
- Selection of scrambled service

See the IP output module user guide for further information.

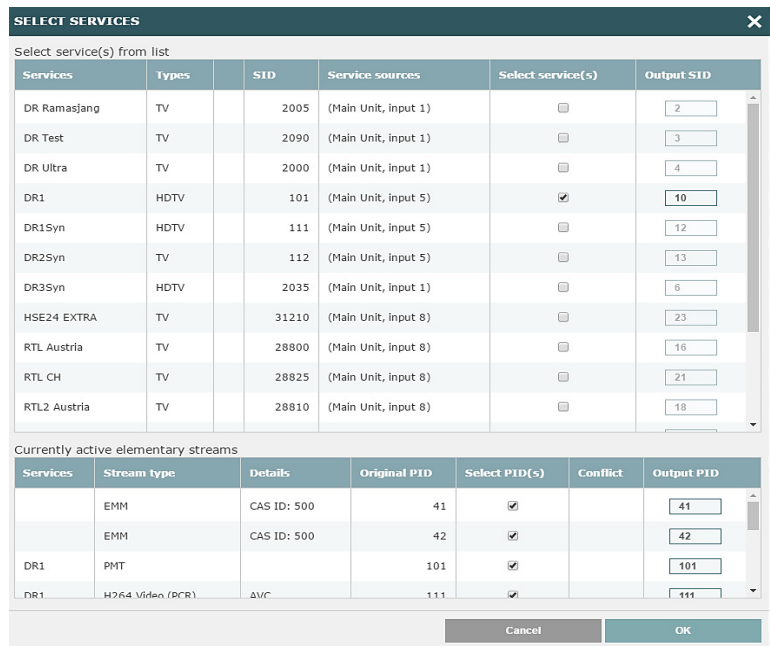
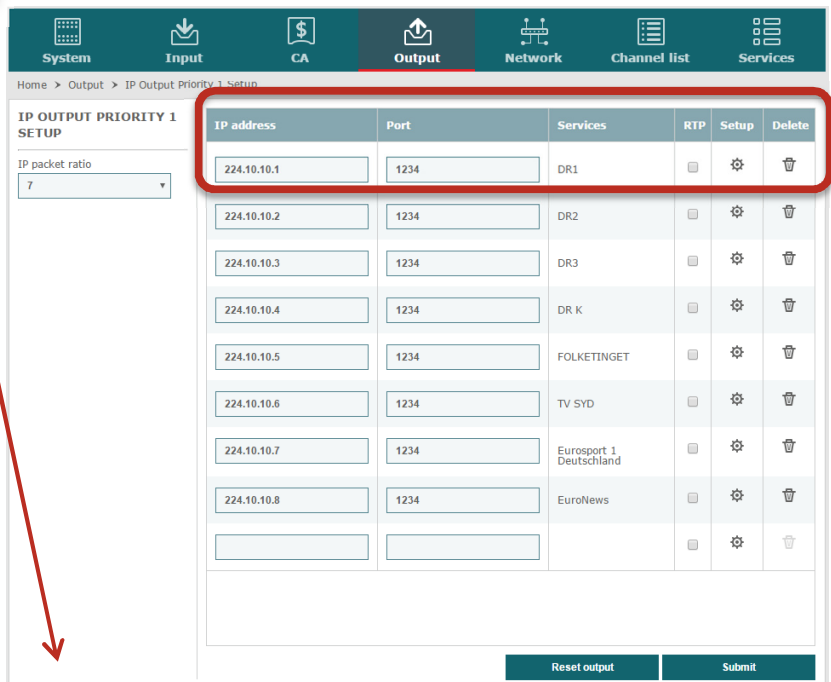
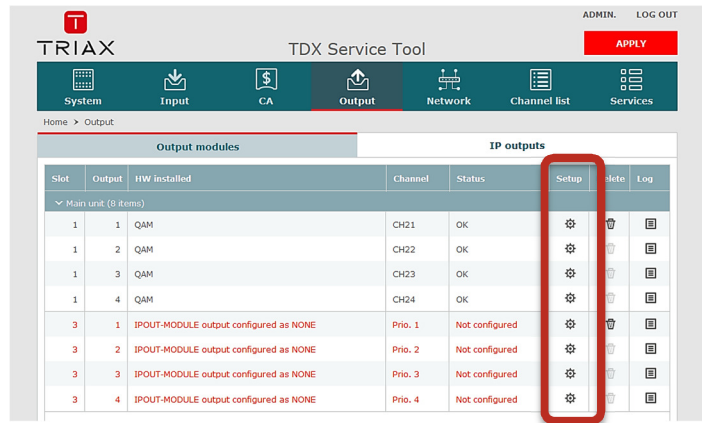

8. View the **Status information** area, down below, to see the following:
 - The link's RTP status
 - The transfer bitrate
 - The number of license services used.
 - The total number of purchased service licenses
9. Press the **Submit** button.
10. Press the **Apply** button

STATUS INFORMATION

Status: **OK**; SW-Revision: **4.0.1.35773**;

The following message is displayed if the server is busy fulfilling requests from the user:

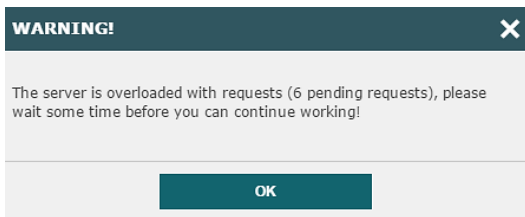

The following message is displayed if more services have been selected than are permitted by the current licenses.

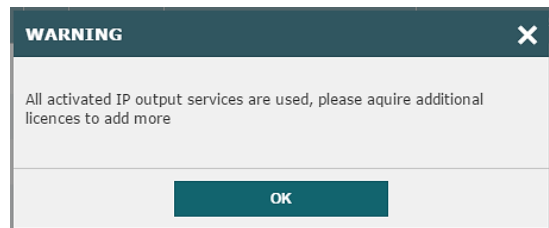

Modifying

To modify and existing IP output configurations:

1. Press the **Setup** button associated with the IP output configuration.
2. Make the required modifications as when creating an IP output configuration.
3. Press the **Submit** button on the IP output setup window.

Press the **Apply** button when the modifications have been made.

Deleting

1. Press the **Delete** button for the IP output to be removed.

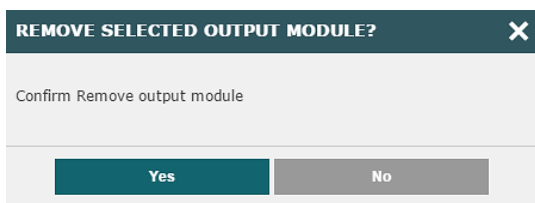

2. Confirm that the selected IP output is to be removed.
3. Press the **Apply** button

Output modules			IP outputs				
Slot	Output	HW installed	Channel	Status	Setup	Delete	Log
Main unit (20 items)							
1	1	NONE output configured as IPOUT-MODULE		N/A	⚙️	🗑️	📄
1	2	NONE output configured as IPOUT-MODULE		N/A	⚙️	🗑️	📄
1	3	NONE output configured as IPOUT-MODULE		N/A	⚙️	🗑️	📄
1	4	NONE output configured as IPOUT-MODULE		N/A	⚙️	🗑️	📄
2	1	QAM		Disabled	⚙️	🗑️	📄
2	2	QAM		Disabled	⚙️	🗑️	📄
2	3	QAM		Disabled	⚙️	🗑️	📄
2	4	QAM		Disabled	⚙️	🗑️	📄
3	1	IPOUT-MODULE output configured as NONE	Prio. 1	Not configured	⚙️	🗑️	📄
3	2	IPOUT-MODULE output configured as NONE	Prio. 2	Not configured	⚙️	🗑️	📄
3	3	IPOUT-MODULE output configured as NONE	Prio. 3	Not configured	⚙️	🗑️	📄
3	4	IPOUT-MODULE output configured as NONE	Prio. 4	Not configured	⚙️	🗑️	📄

If you want to distribute EIT information in connection with your IP output, you can choose between:

- distributing EIT information with every single IP service, or
- use a barker channel for carrying all EIT information for the IP output.

The EIT barker channel can be output in two ways depending on how you distribute your IP output:

IP output method

IP output is distributed through the Link sockets.



IP output is distributed through an IP output module.



Barker channel distribution method

EIT barker channel is output through Link 2 on the main unit

EIT barker channel is output through the AUX socket on the first IP output module in the headend system

EIT – every IP service

1. Select the **Network** tab in the Service Tool.
2. Open the **EIT** drop-down list.
3. Select "Full Actual – No other".
4. Press the **Submit** button.
5. Press the **Apply** button.

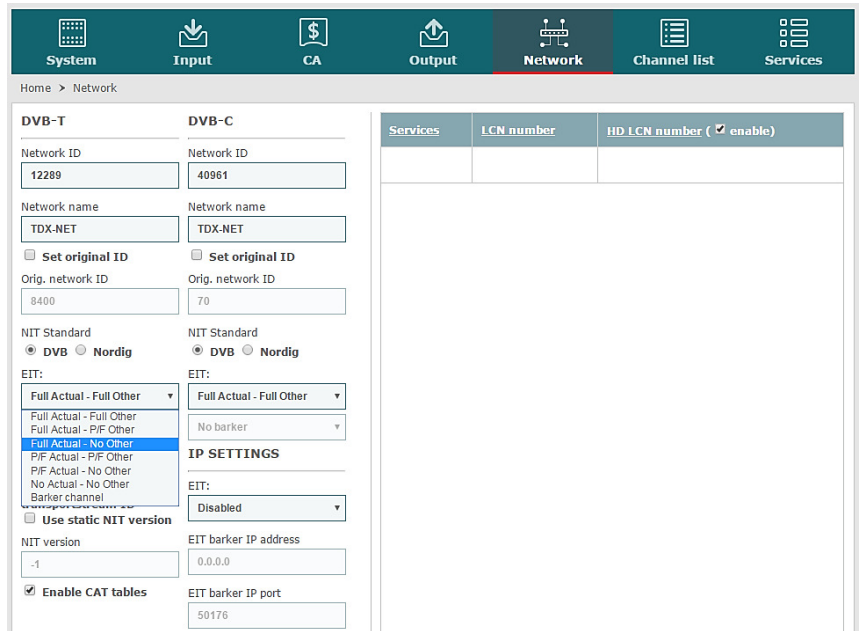

The screenshot shows the 'Network' configuration page in the Service Tool. It is divided into two columns: 'DVB-T' and 'DVB-C'. The 'DVB-T' column has the following settings: Network ID (12289), Network name (TDX-NET), Set original ID (unchecked), Orig. network ID (8400), NIT Standard (DVB selected), EIT dropdown (open with 'Full Actual - No Other' selected), Use static NIT version (checked), NIT version (-1), and Enable CAT tables (checked). The 'DVB-C' column has: Network ID (40961), Network name (TDX-NET), Set original ID (unchecked), Orig. network ID (70), NIT Standard (DVB selected), EIT dropdown (No barker), IP SETTINGS (EIT: Disabled, EIT barker IP address: 0.0.0.0, EIT barker IP port: 50176). On the right, there is a table with columns: Services, LCN number, and HD LCN number (enable checked).

EIT – barker channel

1. Select the **Network** tab in the Service Tool.
2. Open the **EIT** drop-down list.
3. Select "Barker channel".
4. Specify the IP address for the EIT barker channel in the **EIT barker IP address** field.
5. Specify the associated port number in the **EIT barker IP port** field.
6. Press the **Submit** button.
7. Press the **Apply** button.

NOTE:
The IP address used for the barker channel must not conflict with any of the IP addresses used for service distribution.

The **Network** window now contains a single line of information stating which unit and socket is used by the EIT barker channel.

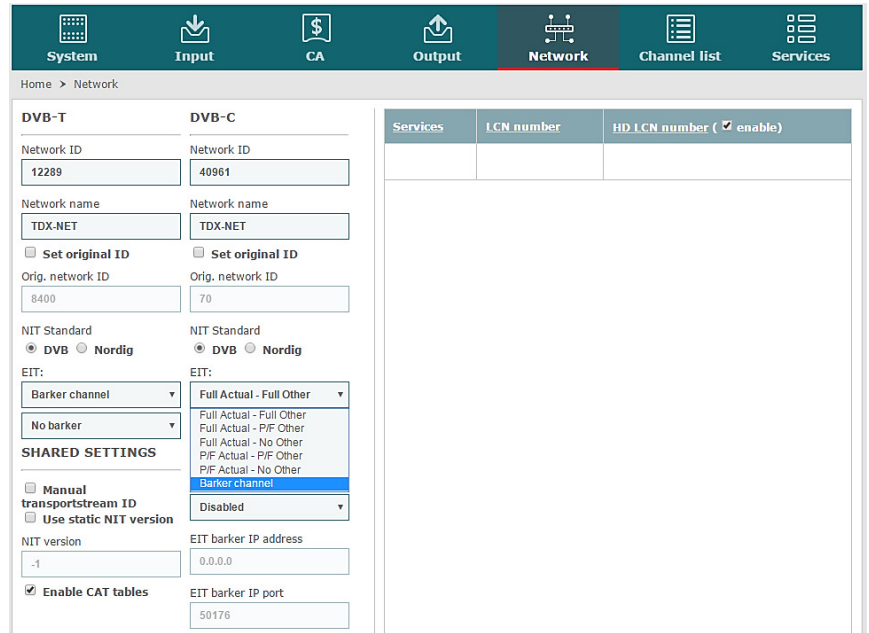

The screenshot shows the 'Network' configuration page. The top navigation bar includes System, Input, CA, Output, Network (selected), Channel list, and Services. The main content area is divided into two columns for DVB-T and DVB-C settings. The DVB-T column has fields for Network ID (12289), Network name (TDX-NET), and Orig. network ID (8400). The DVB-C column has fields for Network ID (40961), Network name (TDX-NET), and Orig. network ID (70). Both columns have NIT Standard options (DVB selected) and EIT dropdown menus. The DVB-T EIT dropdown is set to 'Barker channel'. Below these are 'SHARED SETTINGS' including 'Manual transportstream ID', 'Use static NIT version', and 'Enable CAT tables' (checked). At the bottom, there are fields for 'EIT barker IP address' (0.0.0.0) and 'EIT barker IP port' (50176). On the right, a table with columns 'Services', 'LCN number', and 'HD LCN number (enable)' is visible but empty.

From S/W version 4.0.1 it is possible to filter or even remap the PID.

1. Find output and press SERVICES button.
2. A box opens – by pressing the SELECT SERVICES you can select/deselect specific services.
3. It is also possible to change the output PID – remember however that all PID's shall be different.

Example:

- Press button SERVICES
- At the shown QAM output, there is the following services: 3SAT, KIKA, ZDF, zdf-kultur, zdf-neo and zdf-info.
- Enable the "beauty TV" service
- Now you can see the elementary streams that comes with the service
- You can choose to hide the audio by uncheck the PID (3072)
- You can also choose to remap the Video PID from 3071 to 3099
- Press OK
- Remember to uncheck the field "disabled output" at the previous screen.

Home > Output > QAM output setup

QAM OUTPUT SETUP
(Main unit - Slot 2 - Output 1)

Disabled output

Channel plan: B/G | Channel: Frequency | Frequency (KHz): 0 | Channel spacing: 8 MHz

Select input: Services | RF level correction: +0 dB | Symbol rate: 6875

QAM Mode: 64-QAM | Transportstream ID: 20

Manual SDT version: -1

SELECT SERVICES

Select service(s) from list

Services	Types	SID	Service sources	Select service(s)	Output SID
3sat	TV	28007	(Main Unit, input 3)	<input type="checkbox"/>	2
Beauty TV	TV	54	(Main Unit, input 4)	<input checked="" type="checkbox"/>	8
Channel21	TV	769	(Main Unit, input 4)	<input type="checkbox"/>	12
Comedy Central / VIVA AT	TV	60	(Main Unit, input 4)	<input type="checkbox"/>	5
DELUXE MUSIC	TV	65	(Main Unit, input 4)	<input type="checkbox"/>	10
DMAX Austria	TV	73	(Main Unit, input 4)	<input type="checkbox"/>	11
KIKA	TV	28008	(Main Unit, input 3)	<input type="checkbox"/>	3
N24 Austria	TV	53	(Main Unit, input 4)	<input type="checkbox"/>	7
ZDF	TV	28006	(Main Unit, input 3)	<input type="checkbox"/>	2
zdf.kultur	TV	28016	(Main Unit, input 3)	<input type="checkbox"/>	6
zdf_neo	TV	28014	(Main Unit, input 3)	<input type="checkbox"/>	4

Currently active elementary streams

Services	Stream type	Details	Original PID	Select PID(s)	Conflict	Output PID
Beauty TV	PMT		100	<input checked="" type="checkbox"/>		100
Beauty TV	Video (PCR)		3071	<input checked="" type="checkbox"/>		3071
Beauty TV	Audio	DEU	3072	<input checked="" type="checkbox"/>		3072

Mux name: Cancel OK

COFDM OUTPUT SETUP
(Unit 1 - Slot 2 - Output 1)

Disabled output

- Press "SUBMIT" and then "APPLY"
- This way it is possible to have full control over the PID's of a specific stream

Currently active elementary streams

Services	Stream type	Details	Original PID	Select PID(s)	Conflict	Output PID
Beauty TV	PMT		100	<input checked="" type="checkbox"/>		100
Beauty TV	Video (PCR)		3071	<input checked="" type="checkbox"/>		3099
Beauty TV	Audio	DEU	3072	<input type="checkbox"/>		3072

Mux name: Cancel OK

SNMP traps

PowerUp	OID:	1.3.6.1.4.1.41359.1.1.1.1
Trap generated when the TDX will be power cycled.		
Login	OID:	1.3.6.1.4.1.41359.1.1.1.2
Trap generated when the web configurator is logged on.		
Logout	OID:	1.3.6.1.4.1.41359.1.1.1.3
Trap generated when the web configurator is logged out.		
TimeOut	OID:	1.3.6.1.4.1.41359.1.1.1.4
Trap generated when the web configurator is timed out.		
FailedLogin	OID:	1.3.6.1.4.1.41359.1.1.1.5
Trap generated when the web configurator login has failed.		
Restart	OID:	1.3.6.1.4.1.41359.1.1.1.6
Trap generated when TDX is restarted.		
InputError	OID:	1.3.6.1.4.1.41359.1.1.1.7
Trap generated when an input module has an error, e.g. module no longer locked to frequency, missing module etc,		
CIInsertion	OID:	1.3.6.1.4.1.41359.1.1.1.8
Trap generated when a CI module is inserted in the TDX.		
CIRemoval	OID	1.3.6.1.4.1.41359.1.1.1.9
Trap generated when a CI module is removed from the TDX.		
ModuleInsertion	OID	1.3.6.1.4.1.41359.1.1.1.10
Trap generated when an input or output module is inserted.		
ModuleRemoval	OID	1.3.6.1.4.1.41359.1.1.1.11
Trap generated when an input or output module is removed.		
CIDescramblingError	OID	1.3.6.1.4.1.41359.1.1.1.12
Trap generated when a service descrambling has an error.		
CICommunicationDown	OID	1.3.6.1.4.1.41359.1.1.1.13
Trap generated when communication with CI module fails.		
VideoDecodingError	OID	1.3.6.1.4.1.41359.1.1.1.14
Trap generated when video decoding of a service in a PAL output module fails.		
InterlinkDisconnect	OID	1.3.6.1.4.1.41359.1.1.1.15
Trap generated when main unit loses connection to a subunit.		
ConfigurationChangeApplied	OID	1.3.6.1.4.1.41359.1.1.1.16
Trap generated when the user applies changes in the web configurator.		
InputOK	OID	1.3.6.1.4.1.41359.1.1.1.17
Trap generated when an input module error disappears, e.g. errors that can disappear are input module no longer locked to frequency, missing module etc,		
CIDescramblingOK	OID	1.3.6.1.4.1.41359.1.1.1.18
Trap generated when a service descrambling error disappears.		
CICommunicationUP	OID	1.3.6.1.4.1.41359.1.1.1.19
Trap generated when communication with the CI module no longer fails.		
VideoDecodingOK	OID	1.3.6.1.4.1.41359.1.1.1.20
Trap generated when a video decoding of a service in PAL output module no longer fails.		
InterlinkConnect	OID	1.3.6.1.4.1.41359.1.1.1.21
Trap generated when a main unit is connected to a subunit		

Manufacturer

Dear Customer

Should you require technical assistance in the event that your expert dealer is unable to help you, please contact us at:

Triax A/S	Tel.: +45 76 82 22 00
Bjørnkærvej 3	mail: triax@triax.dk
8783 Hornsyld	web: www.triax.dk
Denmark	

This page is intentionally left blank !

Diese Seite ist mit Absicht leer !

Cette page a été laissée blanche intentionnellement !

Esta página se ha dejado en blanco intencionalmente !

Denne side er med vilje efterladt tom

For further information
and updated manuals go to

triax.com/support

