

# Stream like at home: The AXING Chromecast solution

Perfect for hotels - Offer your guests personalised streaming directly to the hotel TV set, flexibly as stand-alone or integrated into the Axing middleware.

## Make your guests feel at home!

Just like at home, guests at your hotel can use all their favourite streaming apps without having to log in to the TV. The AXING Chromecast solution makes it easy for your guests to stream their own content. And this is how it works:

### Stream in just three steps:

- ✓ Connect to the hotel WiFi
- ✓ Scan the QR code on the TV
- ✓ Stream content from your favourite app

The clear user interface guides guests through the process with ease. So no questions remain unanswered!



## Available devices and systems:

ISW 2-130	AXING CAST solution   Hardwareserver
ISW 2-132	AXING CAST licences per Chromecast device*
ISW 2-133	Onboarding support for customer, short training/introduction, assistance with setup and integration into the hotel network, max. 7 hours included



## Guests' own content on the hotel TV

For a long time, hotel entertainment was limited to TV channels and video on demand. With Chromecast technology, guests can now enjoy their own content as well as that of all major streaming providers on the hotel TV. They can use their favourite apps such as Netflix, YouTube, Disney+, Amazon Prime Video, DAZN and many more on their smartphone as usual.

Using the casting feature of the respective app, the content can simply be played on the TV without having to download an additional (hotel) app. The Chromecast standard works on Android and iOS

\* The software is a one-time licence without annual/monthly follow-up costs.



# Solutions

The AXING Cast Server manages the Google Chromecasts in your network so that only the respective user of the room brings their content securely to the screen.

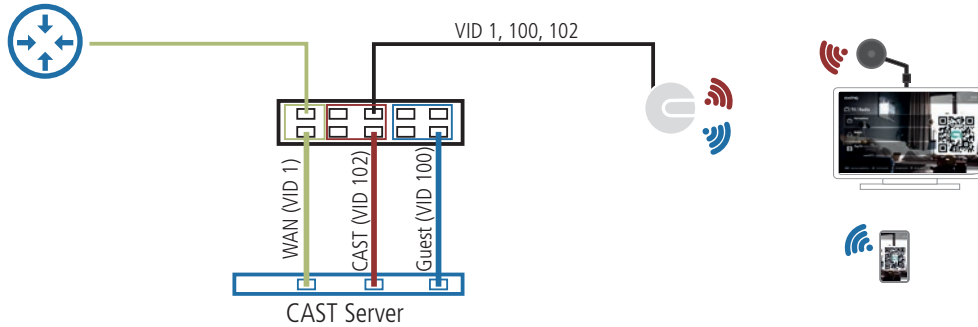

Guest network and cast network are separated by VLAN structure.

The AXING Chromecast solution can be used stand-alone or in conjunction with the AXING middleware.

## Chromecast Solution with DVB-S/C/T

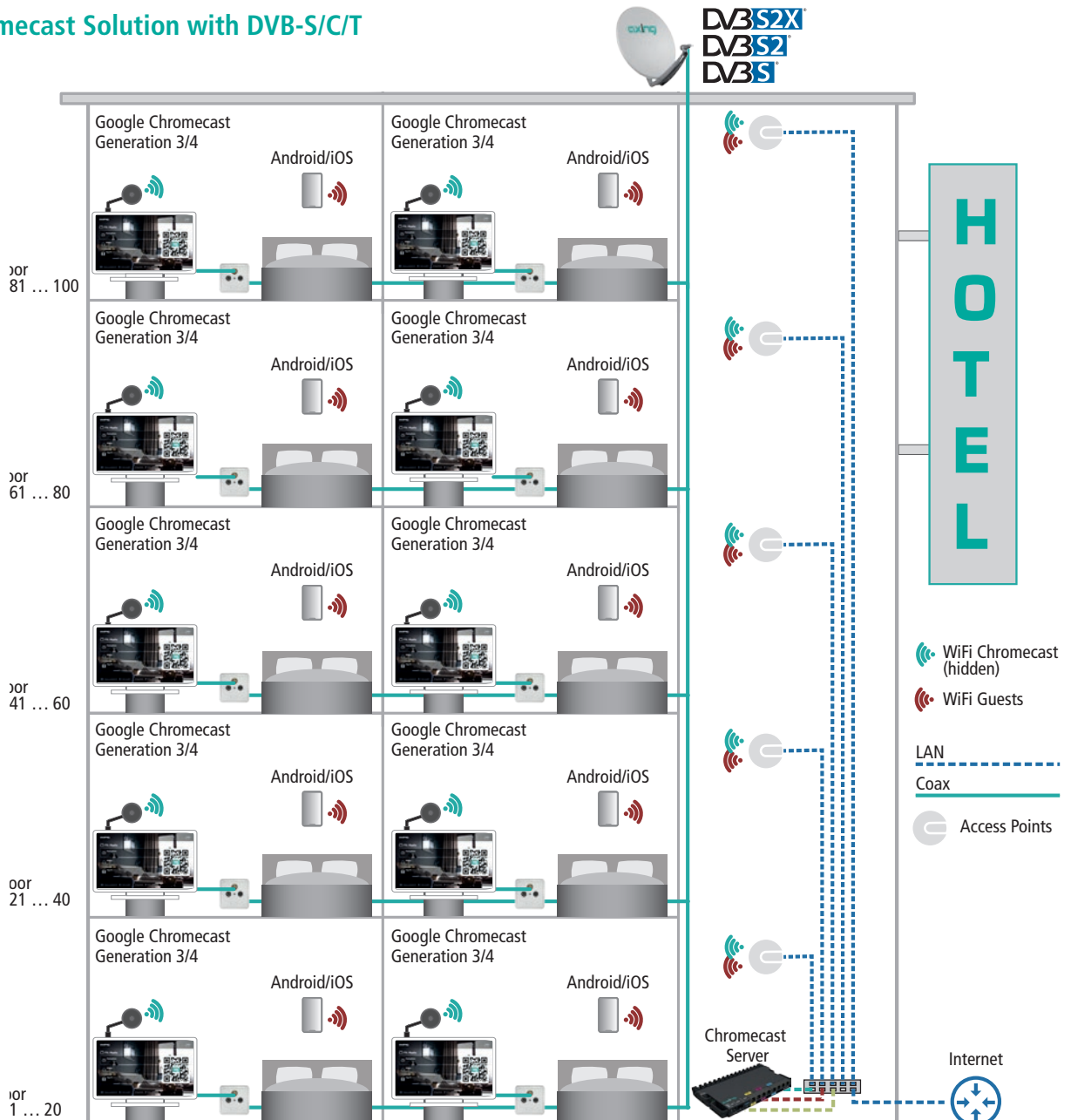

## Chromecast Solution with IPTV and Middleware

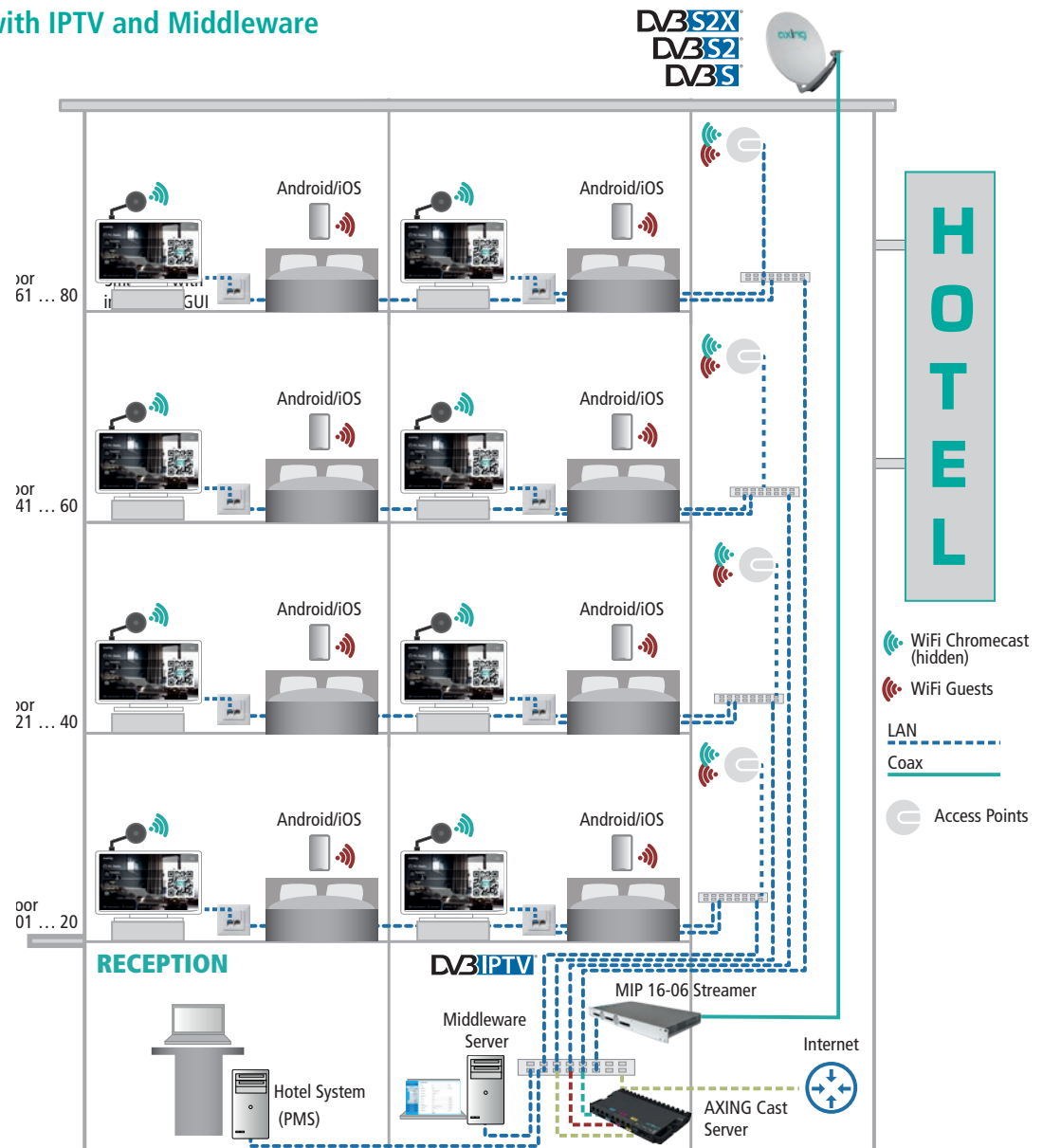

### Configuration and monitoring

Thanks to the management software, you always have an overview. This gives you an insight into the bandwidth used, monitors the status of the built-in Chromecast and allows you to analyse the usage of your guests anonymously with statistics. The server also ensures the correct allocation of Chromecast devices and protects guests' personal data.

### Implementation

The Chromecast system is easy to implement and consists of two components: The AXING Cast Server as the central gateway and the Chromecast devices. All that is required is an HDMI connection to the relevant hotel TVs and a hotel-wide Wi-Fi network.

### Data protection

Data protection is our top priority: with the AXING solution, the cache is cleared and the history deleted every time a guest checks out, so that the next guest cannot view it and finds the user interface for connecting again.

### Theft protection

The clever bracket mounts the Chromecast firmly to the TV and prevents theft or unauthorised resets of the Chromecast by your guests.



## Global Partnerships, Local Excellence – Join the Axing Network

**Your Opportunity:** Are you seeking to become a local distributor for cutting-edge TV and broadband solutions in your region? Connect with Ünal Isler or Zaher Al-Hayek, our dedicated regional sales managers, to explore how we can collaborate and bring innovative solutions to your market.

### Your contact partners:

#### MENA

#### Zaher Al-Hayek

AXING Middle East  
Mobile 00971 55 1389 000  
E-Mail z.alhayek@axing.com



#### Rest of the World

#### Ünal Isler

International Senior Sales  
Manager  
Mobile +49 160 7013393  
E-Mail u.isler@axing.com



## Existing distributors

