

Wireless Bridge User Manual



Model: CPE206 | CPE355

Thank you for purchasing our product.

Please read the user manual carefully before use. Any problems, please contact your supplier.

1. Typical Application

1.1 Typical Application

Extend Your Network

5.8G wireless bridge is very suitable to extend the home network to your barn, garage, warehouse. Extend the video surveillance range without the complicated wiring.



Our wireless bridges not only help you build remote monitoring systems but also help you extend your network signal to warehouses, barns, garages and other buildings near your home.

1.2 Construction of Wireless Bridge System

1) Point to Point Connection:

A. Point to point long range video surveillance

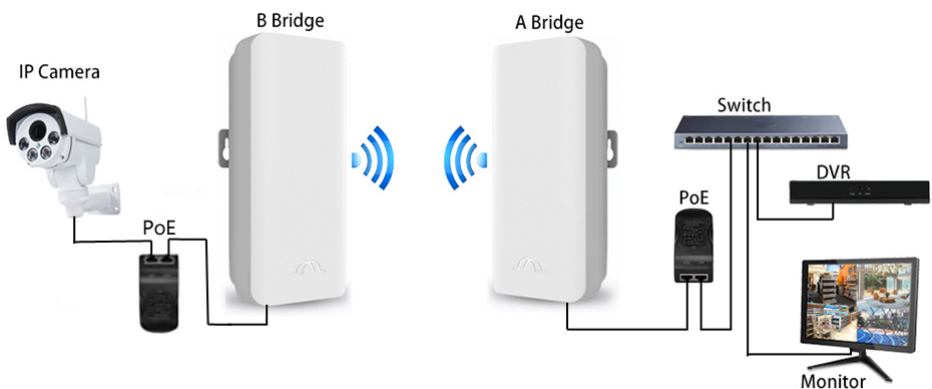

B. Point to point long range network extension

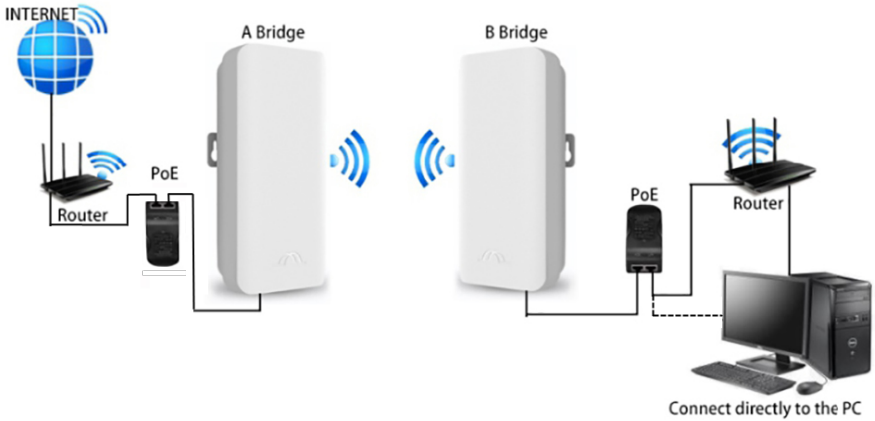

C. Multiple network equipment with long range access

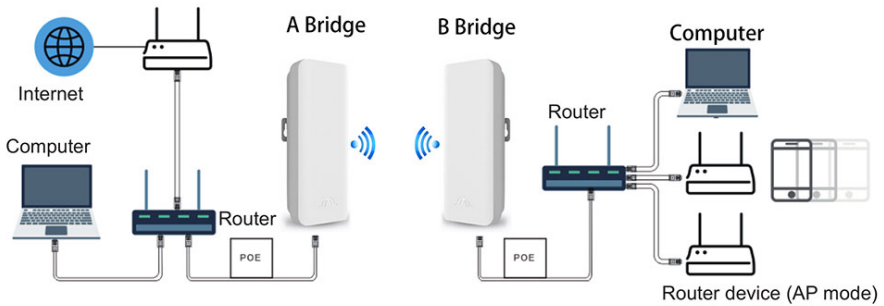

2) Multiple Client Connections

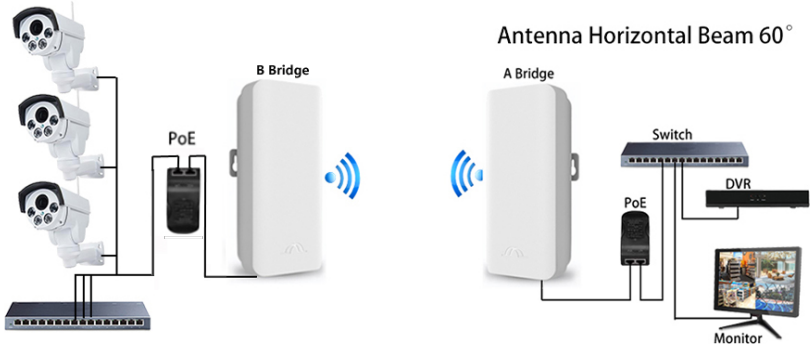

2. Wireless Bridges Main Features:

- 1) Long-distance 5.8G wireless transmission
- 2) Supports point-to-point and point-to-multipoint mode
- 3) Compatible with both WDS networking mode and video networking mode
- 4) Supports auto-configure the transmitter and receiver, and also supports PC connection to finish settings.
- 5) Dynamic MIMO power saving mode (DMPS) and automatic power saving transmission (APST)
- 6) Pre-configured wireless bridge, plug and play.
- 7) Supports 24V POE power supply, convenient installation and deployment, simple construction, safe and reliable.
- 8) Wireless bridges can be repositioned and reused, flexible and cost effective.

3. Product Parameters

Model	CPE206 / CPE355
Master Control	Ar9344
DRAM:	DDR2 64MByte
FLASH	8Mbyte
Wire Interface	10/100Mbps LAN*2
CPE Transmission Rate	300Mbps
Transfer Method	Direct Sequence Spread Spectrum (DSSS)
Modulation	OFDM/BPSK/QPSK/CCK/DQPSK/DBPSK
Network Standard	IEEE802.11a, IEEE802.11b, IEEE802.11g, IEEE802.11n
Supporting Agreement	CSMA/CA, TCP/IP, IPX/SPX, NetBEUI, DHCP, NDIS3, NDIS4, NDIS5
Frequency Range	4900-6100MHz
Power Consumption:	3W
Power Supply	POE 24V 0.5A-1A
Antenna Gain:	12DBi/14DBi
Antenna Polarization	Vertical (Horizontal 60°C / Vertical 30°C)
Direction:	Management Settings: WEP management, Telnet, Serial
Encryption	WEP encryption 64/128bits, WPA, WPA2, 802.1x
Operating Temperature:	-30°C ~ 65°C

4. Operation Instruction

The two bridges are pre-paired at the factory. If they do not pair and connect automatically when you receive the product, you can read the following instructions to pair and connect them yourself.

The wireless bridge has two **settings modes**, auto-configuration mode and custom configuration mode.

A. Auto-configuration Mode: Simply connect the bridge with POE adapter and an Internet source, on one select "A" mode and the other select "B" mode. Keep the master and slave both in the same channel. The two bridges will be paired automatically without any other settings.

B. Custom Configuration Mode: You must be familiar with the network technology, otherwise the bridges may lose the network or it will not work properly. This mode is mainly used for reading parameters and debugging, also can be used to configure point-to-multipoint video surveillance or network expansion (reserved function).

We strongly recommend you choose auto-configuration mode when you use this product for the first time. You can switch to custom mode after you understand the network settings.

4.1 Product Overview

The functions of CPE355 wireless bridge and CPE206 wireless bridge are basically the same. Their main difference is that the antenna gains and the product wireless connection status indications **are** different.

- 1) **CPE206 wireless bridge antenna gain is 12dBi, its** unobstructed transmission distance is 2km.
- 2) CPE355 wireless bridge antenna gain is 14dBi, its unobstructed transmission distance is 3km.
- 3) The wireless connection of CPE206 wireless bridge is indicated by "Link", while **the CPE355 is indicated by "WLAN"**.

Wireless Bridge Details

300Mbps | **5.8**GHz | **3000**M

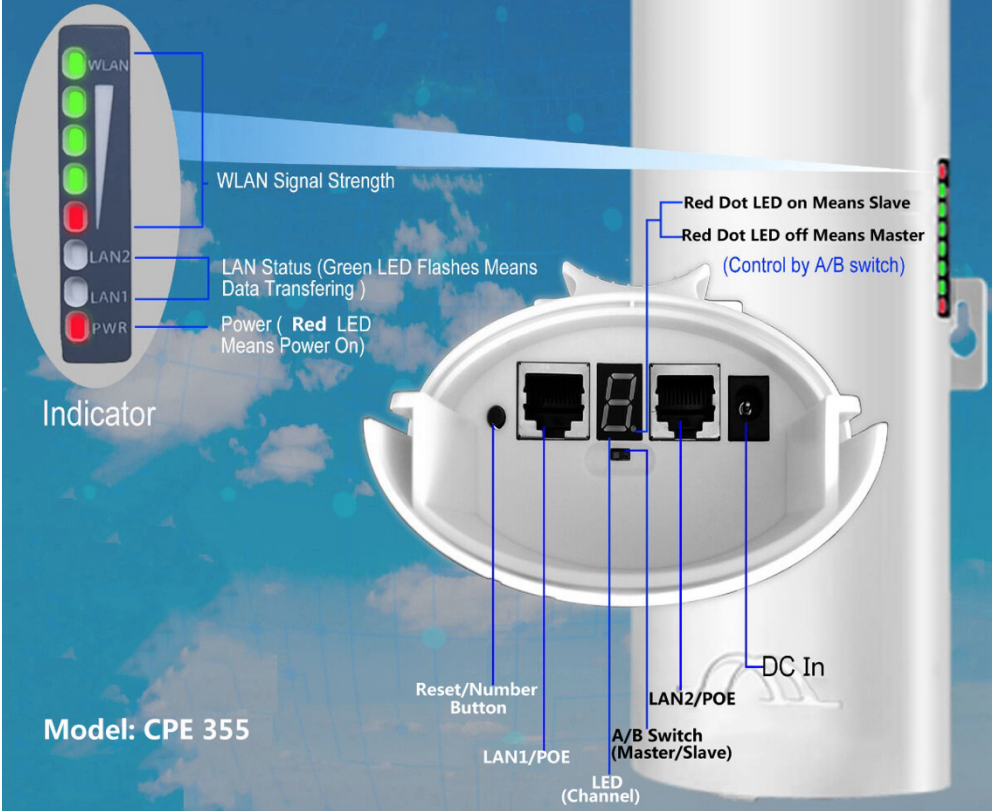

Model: CPE 355

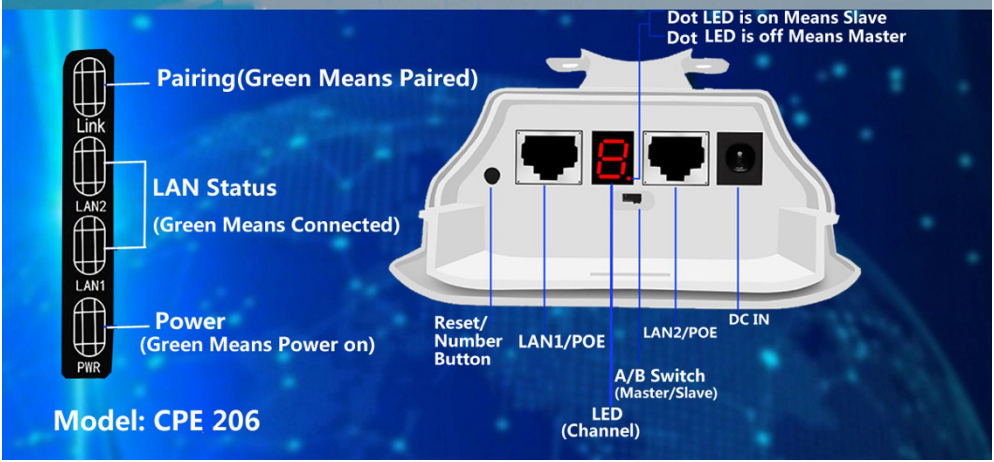

Model: CPE 206

4.2 LED Indication & Function Chart:

WLAN	WLAN solid red light on indicates successful pairing , 4 grid green signal lights indicate the signal strength (Only CPE 355)
Link	Pairing Indicator, Green LED Means Connected (Only CPE 206)
LAN1/LAN2	When the bridge data connection is successful, the LED light will turn on, otherwise it will be off.
PWR	Power indicator, when the bridge connected to power source, the LED turns on.
LED Display	<ol style="list-style-type: none"> 1, LED displays "H" indicates in manual configuration status, short press the RST button to auto-configuration; 2, LED displays "L" and flashing indicates auto-configuration status; 3, LED flashing indicates setting the configuration or connecting, solid light on indicates that the pair is successful; 4, The digital LED indicator displays "o" and flashing means the "DIP switch control" on the bridge control panel (UI) is disabled; 5, LED values represent the corresponding IP address and wireless channel.
A/B Switch	"A" position represents the master mode. "B" represents the slave mode.
POE/LAN	24V power supply and 100Mbps data transmission.
LAN	Only data transfer, 10/100Mbps RJ45 port.
Dot LED	When the device is on "B" mode, the light is on. When the device is on "A" mode, the light is off.
RST	<ol style="list-style-type: none"> 1, Short press the RST button to change the channel from 0,1,2,3...D in cycle (E and F Reserved). 2, Long press RST button over 15 seconds, the system will return to factory setting (only LED indicator displays "o" is valid).

4.3 LED Number match to IP & SSID & Channel Chart:

LED Value	(A)Master Mode IP	(B)Slave Mode IP	Channel ID	WiFi SSID	Password
0	192.168.255.100	192.168.255.200	0	CPE5G_5G0	zllinkcpe1234560
1	192.168.255.101	192.168.255.201	165	CPE5G_5G165	zllinkcpe123456165
2	192.168.255.102	192.168.255.202	161	CPE5G_5G161	zllinkcpe123456161
3	192.168.255.103	192.168.255.203	157	CPE5G_5G157	zllinkcpe123456157
4	192.168.255.104	192.168.255.204	153	CPE5G_5G153	zllinkcpe123456153
5	192.168.255.105	192.168.255.205	149	CPE5G_5G149	zllinkcpe123456149
6	192.168.255.106	192.168.255.206	48	CPE5G_5G48	zllinkcpe12345648
7	192.168.255.107	192.168.255.207	44	CPE5G_5G44	zllinkcpe12345644
8	192.168.255.108	192.168.255.208	40	CPE5G_5G40	zllinkcpe12345640
9	192.168.255.109	192.168.255.209	36	CPE5G_5G36	zllinkcpe12345636
a	192.168.255.110	192.168.255.210	140		
b	192.168.255.111	192.168.255.211	132		
c	192.168.255.112	192.168.255.212	124		
d	192.168.255.113	192.168.255.213	116		
e(Reserved)	192.168.255.114	192.168.255.214	108		
f(Reserved)	192.168.255.115	192.168.255.215	100		

4.3. Auto-Configure Wireless Bridges

4.3.1 Connect Wireless Bridge Master to POE Adapter

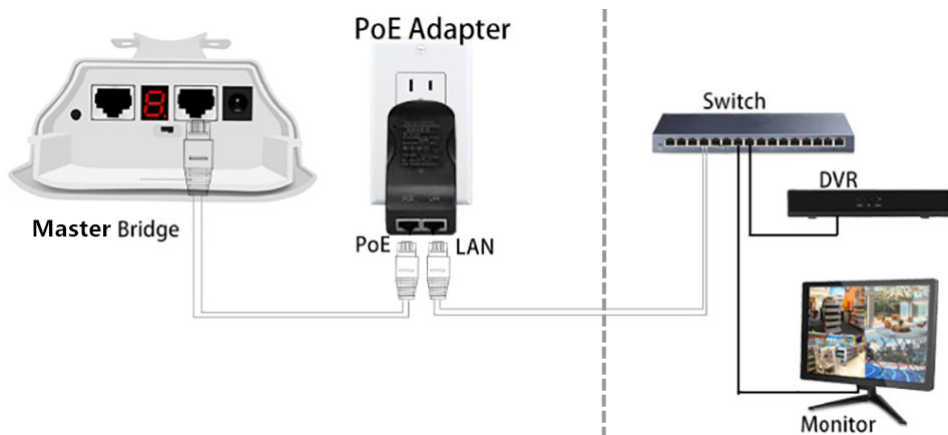

4.3.2 Connect Wireless Bridge Slave to POE Adapter

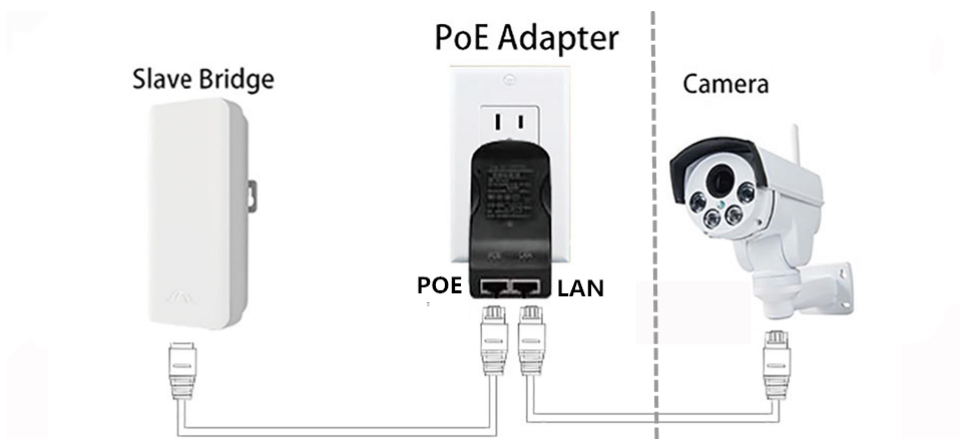

4.3.3 Pairing the **Master and Slave Mode**

Pairing is simple enough by pressing the small button on the bottom of the unit then pressing the button on the other unit within 60s. Please refer below:

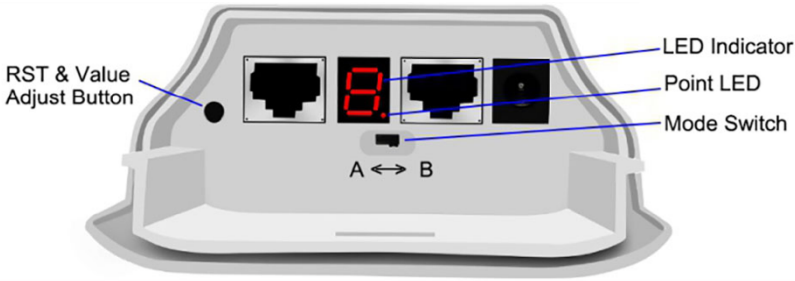

- a) Switch to “A” position, the device works on master mode, **the Point** LED is off;
- b) Switch to “B” position, the device works on slave mode, **the Point** LED is on.
- c) Connect the POE and plug the POE in AC power, **wait** patiently for them to power on, about 2 minutes.
- d) Short press the RST button to change the channel from “0” - “D”, the LED indicator will display the numeric to show what channel it is, please keep the master and slave both in the same channel. The bridges will automatically complete the pairing.

Wireless Bridge Details

300Mbps | **5.8**GHz | **3000**M

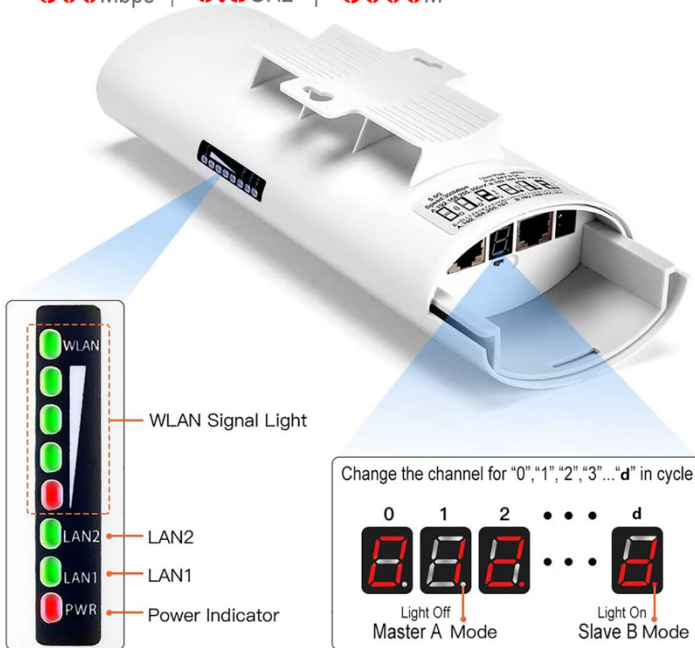

Note: **The** bridges are pre-paired, just connect to POE adapter, it will auto pair in a few minutes. If you want to change the channel, **please** short press RST to re-pair it.

4.3.4 Wireless Bridges Auto-pairing and Debug Example

1. Unbox everything.
2. Switch one unit to A and the other unit to B.
3. Connect the POE to each unit using the Ethernet cable and plug the POE in.
4. Wait patiently for them to power on, about 2 minutes.
5. Use the tiny RST button to click until you get a channel. 0,1, 2 ...A,B,C... For example, select "7", the LED indicator will display "L" for about 8s, then the numeric "7" flashes every second, means the setting is ok, wait for pairing. Then do the same on the other device. Both devices need to be on the same channel.
6. You should see them sync.
7. Plug the cable from your router into the LAN port of the POE connected to unit A.
8. Plug the computer cable into the LAN port of the POE connected to unit B.
9. Enjoy the internet access.

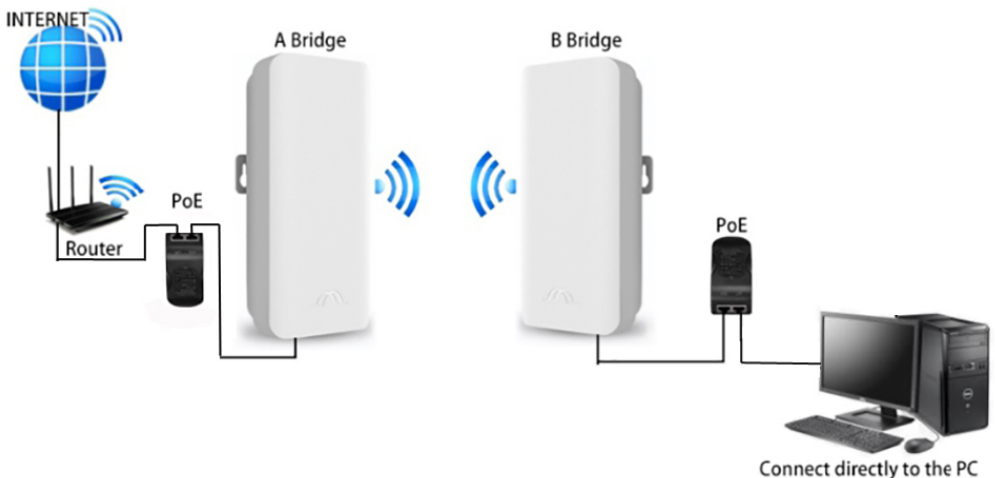

4.4. Install Wireless Bridge

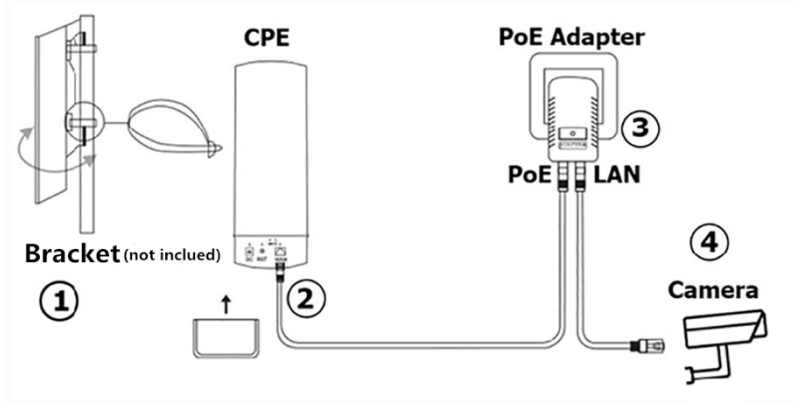

- 1) Put the bridges front side face to face in the same direction (the bracket is not included.)
- 2) Connect the LAN port of the bridge to the POE port of the POE adapter. The POE adapter provides power and data transmission for the bridge. It's recommended to use a Cat 5e (or above) shielded network cable with a ground wire.
- 3) The LAN port of the POE adapter connects to monitors or the internet for master bridge.
- 4) The LAN port of the POE adapter connects to cameras or other equipment for the slave bridge.

4.5. Custom Configure Wireless Bridges

4.5.1 Connect the Wireless Bridges to POE adapter and PC

- 1) Connection the POE port of the power adapter to the LAN port of the wireless bridge;
- 2) Connection the LAN port of the power adapter to the LAN port of the computer;



3) Check the wireless bridge mode switch is at “A” position or “B” position, reboot the bridge (it would take about 30s, please be patient with it). Check the numeric on the LED indicator of the wireless bridge, for example: the numeric is 8, and the mode switch of the wireless bridge is at “B” position, then the IP address of the wireless bridge is 192.168.255.208. (if the mode switch of the wireless bridge is at “A” position, then the IP address of the wireless bridge is 192.168.255.108, please refer [the 4.3 LED Number match to IP & SSID match to password Chart.](#))



4.5.2 Modify your computer’s IP address to 192.168.255.xxx,(xxx is from 1 -254),

Please be careful, the computer’s IP address cannot be the same as the wireless bridge, and they must be in the same network segment. The following example is based on Windows 7, 8 or 10, for other versions or operating systems, please Google how to do it, it is simple step.

To change the computer’s IP address in Windows, you’ll need to open the “Network Connections” window. Hit Windows+R at the same time,



Type “ncpa.cpl” into the Run box, and then hit Enter.

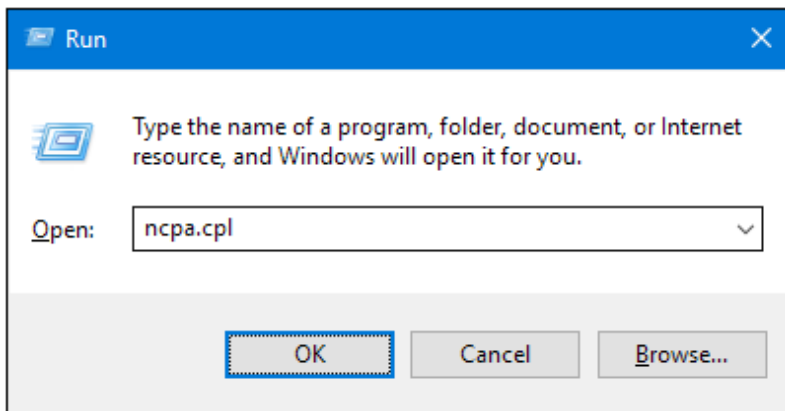

In the “Network Connections” window, right-click the adapter, and then select the “Properties” command.

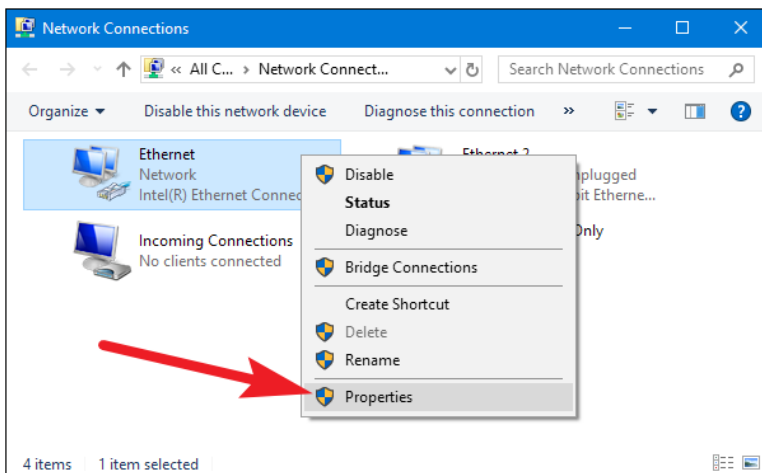

In the properties window for the adapter, select “Internet Protocol Version 4 (TCP/IPv4)” and then click the “Properties” button.

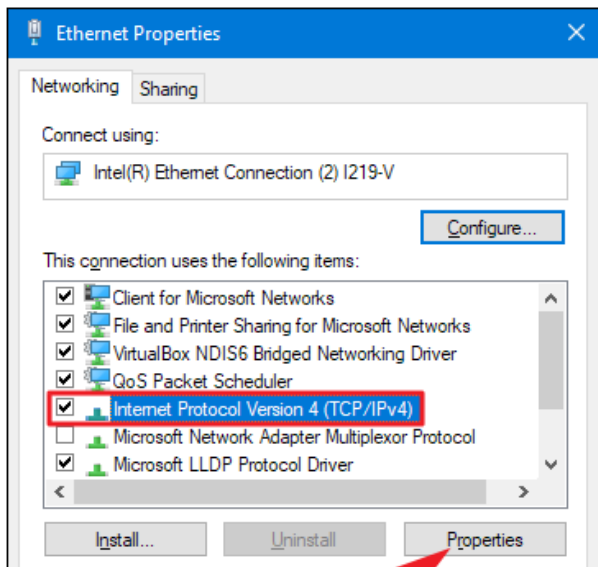

Select the “Use the following IP address” option, and then type in the IP address, subnet mask, and default gateway that corresponds with your network setup. Next, select the “Validate settings upon exit” option so that Windows immediately checks your new IP address and corresponding information to ensure that it works. Then click the “OK” button.

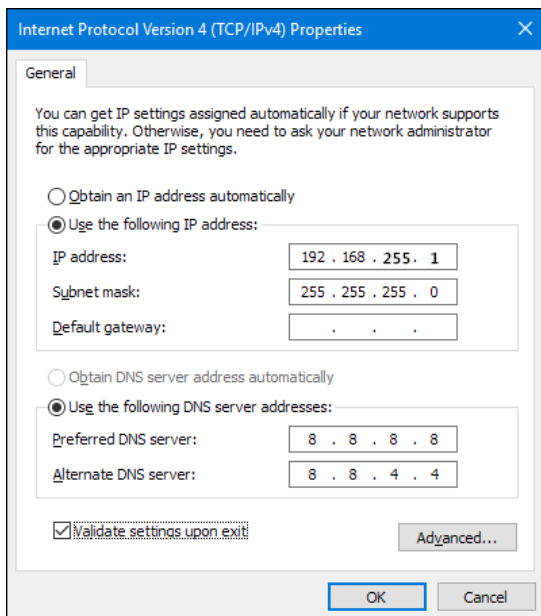

And then close out of the network adapter's properties window.

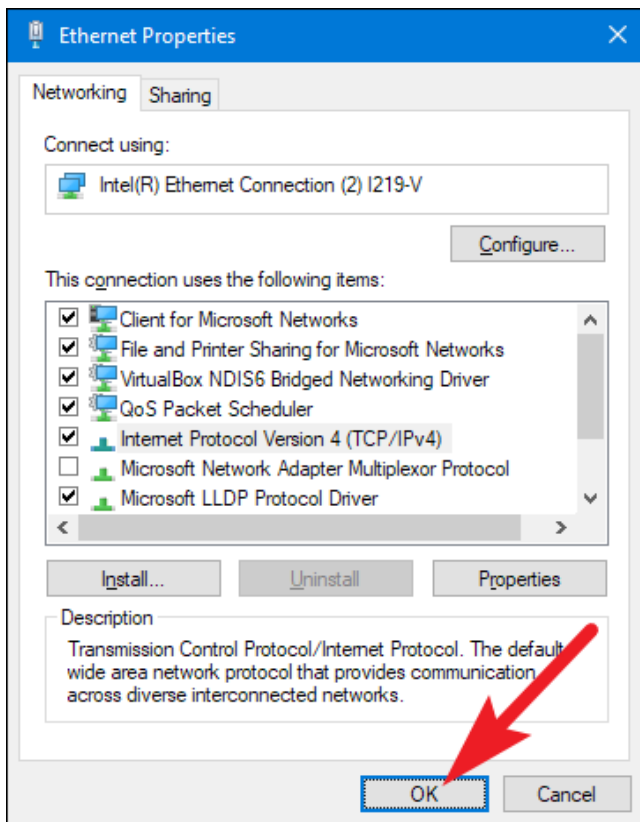

Windows automatically runs network diagnostics to verify that the connection is good. If there are problems, Windows will give you the option of running the Network troubleshooting wizard. However, if you do run into trouble, the wizard likely won't do you too much good. It's better to check that your settings are valid and try again.

4.5.3 Login into master bridge and slave bridge control panel

1) After you modified your computer's IP address, open the browser and enter the IP address of the wireless bridge to access, for example, enter "192.168.255.107" on the browser address column, you can access your bridge control panel.

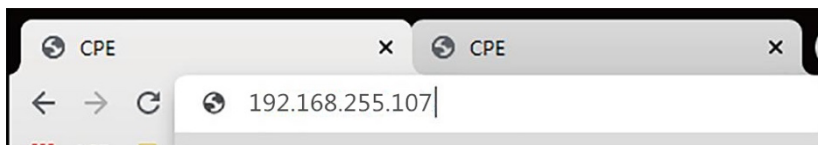

The browser login interface as below diagram:

CPE Login

Username

Password

Login

Language

Note: If enter the IP address, the screen does not display the login interface, please check the network cable connection, and make sure your computer's IP address must be 192.168.255.xxx.

Enter the Username and Password, the default username and password is "admin / admin", select language to "English", click "Login" to confirm and go to the below interface:

The screenshot shows the CPE configuration interface. At the top, there are 'Apply' and 'Cancel' buttons. Below that is a 'CPE' header with 'Logout' and 'Reboot' icons. A left sidebar contains a 'Quick Setup' menu with options: Bridge Setting, Access Point, Station(Repeater), Status, and Setting. The main content area is titled 'Set Password' and includes a 'Set User password:' field with a placeholder 'Please don't use too weak password!'. Below this is an 'Other Settings' section with a 'Region:' dropdown menu set to 'China' and a 'DIP Switch Control:' checkbox checked 'Enable' with a note: 'Read wireless config from hardware DIP switch, when device boot.'

On "Quick Setup" menu, you can modify the user password, click "Apply" button to confirm

TIPS: If you modify the Password, please remember it.

2) Bridge Setting

The screenshot shows the 'Bridge Setting' configuration page. On the left is a sidebar with navigation options: Quick Setup, Bridge Setting (highlighted), Access Point, Station(Repeater), Status, and Setting. The main content area is titled 'Wireless Setting' and contains two sections: 'Wireless Setting' and 'Network Setting'. In the 'Wireless Setting' section, 'DIP Switch Control' is checked (Enable), 'Mode' is set to 'A(Master)', and 'Matching ID' is '44 (5220 MHz)'. The 'Network Setting' section shows 'Fixed IP Address' as '192.168.255.107' and 'Hostname' as an empty field. An 'OK' button is located at the bottom right of the configuration area.

On the bridge setting menu, you can set the bridge parameters

DIP Switch Control: check it to enable auto mode, press the "RST" button is functional, for the operation details please refer **4.2 LED Indication & Function Chart**. Disable it, the "RST" button is not functional, the bridge works in custom mode, you can set the bridge parameters for customized function.

Note: if the "DIP Switch Control" is not on enable, the device works at custom mode, it will not auto pair and "RST" button is not functional, please be careful, it may lose the connection of your bridges after your configured.

If you are not familiar with network technology, please check the "DIP Switch Control" is on enable, system works at auto mode, and do not make any changes.

Mode: you can select A (Master) and B (Slave) mode

Matching ID: you can select bridge working frequencies, please refer the **4.3** chart to find out the number matching to 5.8G frequencies, for example: "44(5220MHZ)", 44 is match as below diagram:

The channel is 7, for (A) master mode the IP address is 192.168.255.107, for (B)slave mode the IP address is 192.168.255.207

Fixed IP address: you can change the bridge's IP address, it must be in this format 192.168.255.xxx, click "OK" button to save the settings. IP address should correspond to the channel one by one, for example, channel 44 corresponds to (A) Master Mode IP(192.168.255.107) and (B)Slave Mode IP(192.168.255.207)

Host Name: you can set the bridge with a special name for remember it.

LED Value	(A)Master Mode IP	(B)Slave Mode IP	Channel ID	WiFi SSID	Password
7	192.168.255.107	192.168.255.207	44	CPE5G_5G44	zllinkcpe12345644

3) Access point and station (repeater)

Access point and station (repeater) is **reserved function**

4) Status

Click "Status" of the left menu, system will display the following interface:

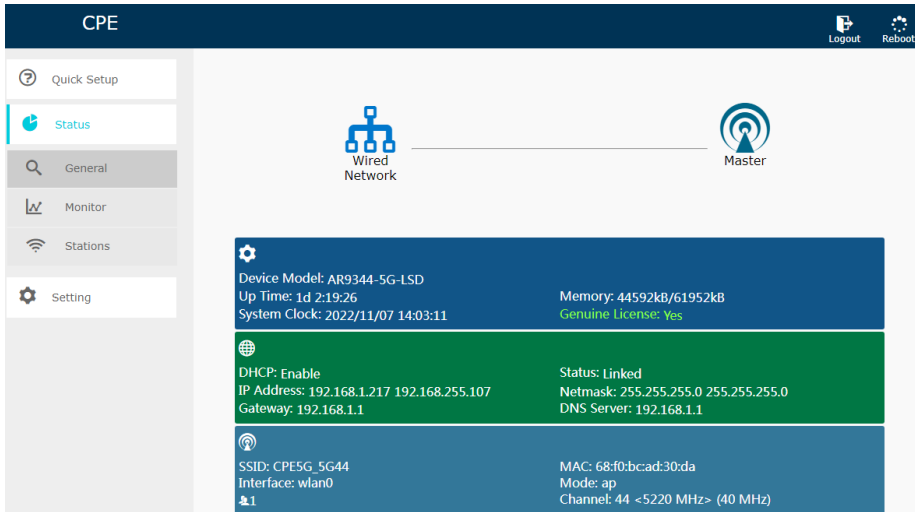

5) Read SSID & Password

When the "DIP Switch Control" is enabled, the bridge has pre-programmed the WiFi hot spot name (SSID) and password, you can click "Setting" of the left menu, and click "wireless" you can view and change the password if needed:

The name and password is pre-programmed, it has different name and password when the bridge works at different channel.

For example: the WiFi hot spot SSID name is "CPE5G_5G44", and the default password is "zllinkcpe12345644", if the name is "CPE5G_5G153", and the password should be "zllinkcpe123456153", the last three numeric of the password is matched to the last three numeric of the SSID name.

Click "Setting" of the left menu, click "Wireless", you can check the settings.

- Wireless
- Network
- System
- Tools

Coverage Distance(m):  Set the value as needed, large value will effect performance. If not set, a default value will be used.

Timed Off: Enable

New Virtual Interface: [Create](#)

Virtual Interface(phy0/wlan0) Settings(Station) ⌵

Switch: Enable Recommended to set channel to auto, when enabled this.

Name (SSID): [Scan](#)

Authorization: ▾

Password:

Fixed BSSID:

Wireless Bridge(WDS): Enable

VLAN:

Delete Virtual Interface: [Delete](#)

Virtual Interface(phy0/wlan1) Settings ⌵

Switch: Enable

Name (SSID): Hidden

Authorization: ▾

Password:

Access Control: ▾

Wireless Bridge(WDS): Enable

5. Troubleshooting

NO	Trouble	Possible issue	Solution steps
1	Packet Latency	<ol style="list-style-type: none"> 1. Wireless interference 2. Distance is too long, or there are some walls between the bridges 3. Wireless bridge install angle in the wrong direction, weak signal 4. The current channel is congested 	<ol style="list-style-type: none"> 1. Use WiFi analysis to choose the best channel, 2. The two wireless bridges should not exceed transmitter distance, avoid the wall 3. Adjust the angle of the bridge according to the signal strength. 4. Choose a new channel
2	Wrong Password	<ol style="list-style-type: none"> 1. Forget the password 2. Input wrong password 3. WiFi password is confused with the WEB access password 	<ol style="list-style-type: none"> 1. Re-input the password 2, User name and password is "admin", The WiFi hot spot password you can find on LED Number match to IP & SSID match to password Chart. 3, Use a dedicated network tool to restore the bridge to its factory configuration.
3	Can't access from computer	<ol style="list-style-type: none"> 1. LAN connection or ethernet cable has issue 2. Local IP is not in the same network segment of the bridge's IP 3. Local IP is taken by other device 	<ol style="list-style-type: none"> 1. Make sure the wireless bridge is connected to the computer and the network cable quality is cat 5e or above and it is in good condition. 2. Set the computer's local IPv4 address to the same of the bridge. For details, please refer to 4.5.2 Modify your computer's IP address. 3. The set IPv4 address is the same as that of other device, so replace it with other IPv4 addresses.
4	System LED light off	<ol style="list-style-type: none"> 1. POE adapter is damaged 2. The bridge's POE port or LED part may broken, 3. Ethernet cable may loose, RJ45 port may incorrect, 4.power current voltage is lower or wrong. 	<ol style="list-style-type: none"> 1. Check the POE adapter or POE switch is works 2. Check the POE port of bridge is good condition 3. Check the Ethernet cable connection, may the Ethernet cable plugged into wrong port, please go back to page for details 4. Check the voltage is correct, if the socket broken, and check the output voltage of the POE adapter is 24V 5. Contact us for replacement items
5	Low transmission Rate	<ol style="list-style-type: none"> 1. Packet Latency 2. Network cable circuit 3. Network virus attack 4. Too much access users 5. Network cables type lower than Cat 5e 	<ol style="list-style-type: none"> 1. Adjust the distance, angle and channel to decrease latency 2. Check if port isolated to avoid network virus and broadcast storm 3. Decrease the access users. 4. Change the Cat 5e or above network cable
6	Device always dead	<ol style="list-style-type: none"> 1. Static electricity 2. Running time too long 3. Lightning stroke 	<ol style="list-style-type: none"> 1. Check the bridge or the POE adapter need a ground connection 2. Running time over 7 days, the system may halt, please reboot it 3. After lightning, the device POE port may broken or unstable, better to deploy the lightning conductor for the bridge. 4. Contact us for replacement items.

6. Technology Support and Service

Thank you for your purchasing our Wireless Bridge, please read the manual carefully before use. If there are any problems during the use, please contact us or your supplier.

1. Accessories are missing in the box;
2. If you can't pair or install it;
3. Damaged wireless bridge or POE power adapter;
4. If the wireless bridge fails or is dead after working for a period of time;
5. No access to the wireless bridge from a computer;
6. The speed provided by the wireless bridge is very slow;

Tech Service email: asked008@outlook.com

Tips:

1. The installation of this device requires network knowledge, if you can't install it, please contact us or ask a professional for help, if the product you receive is damaged or missing any accessories, please contact us for exchange or repair.
2. The wireless transmission maximum speed (wireless bridge A to B unit) is 300Mbps, the LAN network transmission maximum speed (POE adapter to wireless bridge connection) is 100Mbps, the LAN port is 100Mbps standard.

7. Package Included:

- 2 x Wireless Bridges
- 2 x POE Power Adapters
- 2 x Metal straps.
- 1 x User Manual