

Exceptional Headends



Developed and Manufactured in Europe.
Media Player Built-In

Trust TRIAX

Experts in headend technology

Proud heritage

With trailblazing technology at our core for over 75 years, we're proud of where we've come from. And we're proud to keep innovating each day, connecting our customers to the future.

Our headend range is the truest expression of our values of reliability and innovation.

And now, we have a headend to suit the requirements of every installation size and budget.

Unique flexibility and efficiency: Multiplexing via Service Pool technology

TRIAX's innovative Service Pool technology initially loads all incoming signals into the Service Pool (including DVB-S/S2/S2X/T/T2/C/IP). From there, they are fed to several outputs and simultaneously converted into the required output signal.

Multiplexing allows high flexibility. Any service from any input can be routed to any CAM, Scrambler, IP stream, QAM or COFDM outputs and having multiplexing and Service Pool technology at the output module, it is possible to optimise the service line-up and only distribute the required channels.

TV delivered your way

You know what your customers need, and our flexible headends make your choice easy. Whatever your preferred configuration, you can rest assured that each and every TRIAX headend guarantees the same TRIAX quality experience, saving you time and costs, and increasing your own customer loyalty.

Our headends are developed from the ground up at our R&D facility in Denmark, with over 30,000 sold in the last decade alone.

Better viewing experience: EPG Management

TVs display the Electronic Program Guide (EPG) by reading the EPG data on each transponder. If the TV has not yet displayed a service from a given transponder, the corresponding EPG data is not loaded. This will result in blank lines on the EPG. With EPG Management in TRIAX headends, the EPG information of all services can be sent on every transponder.

Therefore a hotel guest can view a complete EPG directly after turning on the TV. In other words, the TV viewer has a better TV experience.

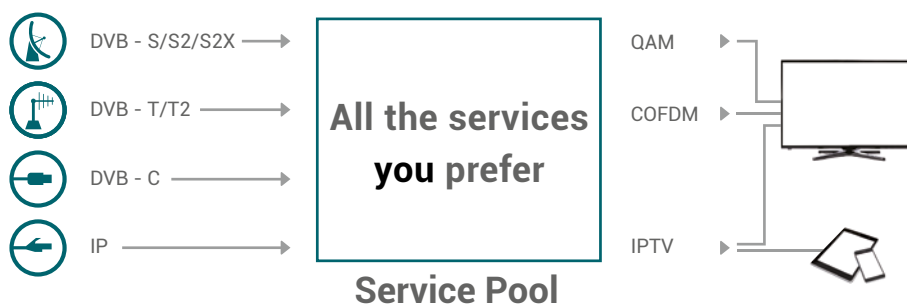

* Input and output options vary on the different headend models.

Possible connections:

- 1 F-conn for DVB-C/T/T2
- 4 F-conn for DVB-S/S2/S2X
- 1 F-conn for test (-20dB)
- 1 F-conn for TV-out (QAM or COFDM)
- 1 SFP for IP IN and IP OUT (UDP/RTP)
- 1 RJ45 for Internet/Cloud/Management
- 1 RJ45 for DRM server
- 4 or 8 PCMCIA for CI cards (4 TdMh, 8 TDcH)
- 1 USB for future use (TDcH only)

— COAX
— IP
— HDMI

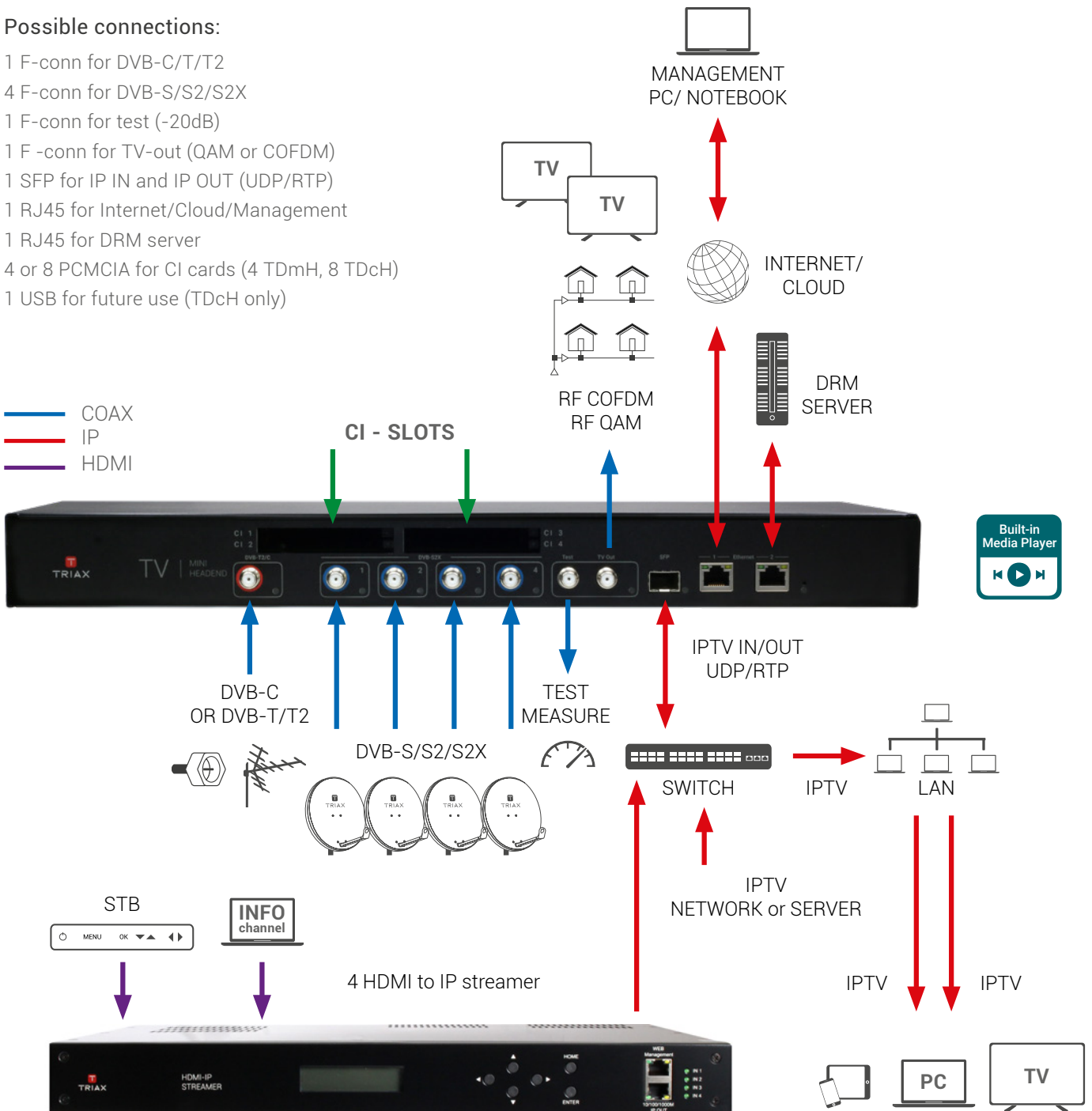

TDmH / TDcH Key Features

1. Built-in Media Player

- Stores and plays media locally (videos, announcements, ads) without a separate server. Extremely low power consumption compared to adding additional server for media playout.
- Separate login offers user-friendly interface for hotel staff for easy and secure handling of media content without extensive technical knowledge.
- Reduces complexity, cabling, and cost.
- Competitors often require external servers for playback that need extra technical setup and maintenance and results in extra cost to hardware and power.

2. Pool / Multiplexing Technology

- Service multiplexing from any source (input, CAM, scrambler) to any destination (CAM, scrambler, output) offering a high flexibility via pool technology.
- CA module slots support more than one transponder simultaneously via pool technology, reducing the need for CA modules.
- Optimises tuner usage → fewer tuners needed → lower cost.
- Scales efficiently across multi-building or multi-floor setups.
- TRIAX service pool technology is a unique feature that offers high flexibility when deploying.

3. Support for SCR switches (Satellite Channel Router)

TRIAX TDcH and TDmH headends support SCR (Satellite Channel Router) technology – a unique and efficient way to distribute satellite signals over a single coaxial cable.

Single-Cable Distribution:

- Allows multiple satellite tuners or receivers to operate over one coaxial cable using different user bands (UBs).

Simplified Infrastructure:

- Reduces cabling requirements and installation complexity, especially useful in MDU, hospitality or retrofit projects.

Improved Signal Management:

- Each tuner receives a dedicated frequency slot, avoiding conflicts and ensuring stable performance.

Full Compatibility:

- Supports EN50494 (Unicable I) and EN50607 (Unicable II) standards, making it compatible with a wide range of SCR LNBs and multiswitches.

Optimised for Headend Integration:

- Within TRIAX TDcH and TDmH, SCR support ensures efficient signal pooling and routing between tuners and transponders – minimising hardware use and maximising flexibility.

4. Both RF and IP Output Simultaneously

- Outputs the same content over RF (coax) and IP (Ethernet) at the same time.
- Enables hybrid deployments → older TVs on coax, modern IPTV on IP.
- Smooth migration from RF-based to full IP-based systems.
- Many vendors require choosing either RF or IP or need separate modules, increasing cost and complexity.



Key Advantages

TRIAx TDcH and TDmH are compact and flexible solutions

Both combine low power consumption with highly reliable hardware and advanced and well tested software. They feature built-in media handling and pool-technology with multiplexed frontend / backend and multi-transponder CAM support, with simultaneous RF/IP output.

Both solutions are perfect for hospitality installations, campuses and small-to-medium multi-building installations.

Advantage	What it means / why it is useful
Scalability + Modular Growth	The TDcH is stackable with additional TDcH and TDmH units; multiple configurations/input-output sizes allow starting small and expanding without replacing the headend.
Shared Stable Software Platform	Uses a well-tested software base for high reliability and low maintenance. Designed and tested for running 24/7.
Compact & Space-Efficient Design	Rack-mount/wall-mount options, high density of inputs, CI slots and outputs in compact or mini version saves space for deployment and simplifies installations.
Support for SCR Multiswitches	Reduces cabling and external hardware (cables, multiswitch boxes), saving cost, weight, space, and reducing points of failure.
RF / IF input supporting many installation types	DVB-S/S2/S2X inputs support multistream and similar DVB-T/T2/C inputs support multiple PLP networks.
Flexibility in Inputs, CAM, Scrambling and Outputs	Supports multiplexing and routing satellite DVB-S/S2/S2X inputs, terrestrial/cable DVB-T/T2/C inputs, CI slots, scrambling, QAM or COFDM outputs and IP in/out. From any source to any destination internal service routing and multiplexing offers very high flexibility.
Flexibility in IP network deployment	VLAN support and both IGMP v2 and v3.
Advanced Software Features	PID/SID management, NIT-searching (fast search), EPG management, LCN management, multi-language audio management via filtering and service duplication, descrambling monitoring and error-recovery. Overview via GUI, cvs sheet overview file and M3U for IP-out among others.
Premium Content Protection / DRM Support	Supports Pro:Idiom, Samsung LYNK, Philips VSecure; important for hospitality or regulated content markets.
Approvals	Includes, among others, FRANSAT PRO and Multichoice Africa.
Long Warranty & Support	5-year limited warranty and software updates included.
Energy Efficiency & Reliability	Lower power consumption, temperature-controlled cooling and robust hardware reduce downtime.

New technologies. New benefits

Supports SCR Functionality

- Increases the number of satellite positions that can be received in the TDcH/TDmH to 4 satellite positions.
- Increases the number of international TV services that can be distributed
- Save time, cost and space with minimal cabling; using a TRIAX DCSS LNB eliminates the need for an external multiswitch.
- Reduced hardware for a cost optimised and compact solution

DVB-S2X demodulator

- Supports receiving of multistream

Multiple language service

- Allows for multiple distributions of a service with multiple audio (language) tracks
- User friendly: services will be available on TVs as individual channels without the user having to change language settings

Classic setup with multiple cables and external multiswitch

TRIAX TDcH supporting SCR functionality

Universal Quattro LNB Headend

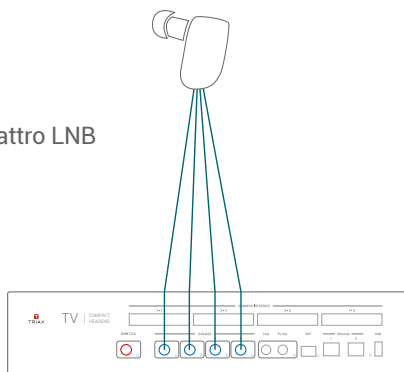

— VS —

SCR LNB Compact Headend with support for SCR Multiswitches

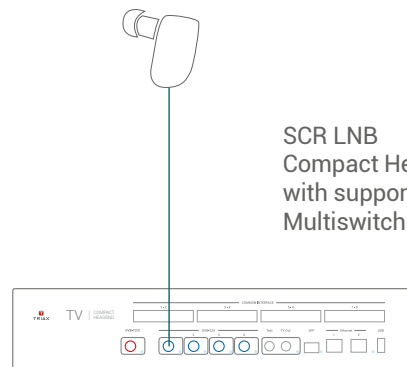

Universal Quattro LNBs Multiswitch Headend

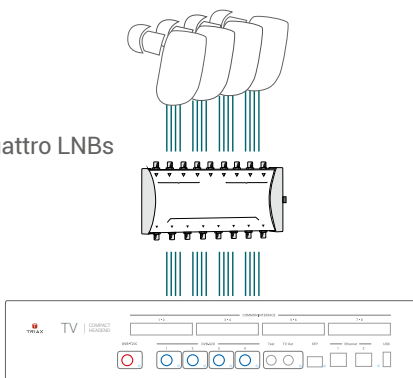

— VS —

SCR LNBs Compact Headend with support for SCR Multiswitches

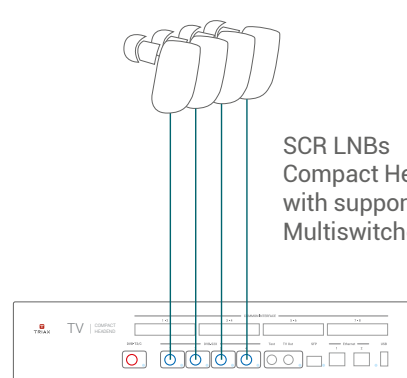

Built-In Media Player

Offers a comprehensive and versatile platform for managing and delivering high-quality media content. With its built-in conversion tool, users can effortlessly convert various source formats – including photos, videos, presentations and PDF files – into playable transport-streams (TS) without the need for external software. This simplifies the workflow and enhances efficiency, allowing users to focus on content creation rather than technical conversion processes.

The player supports high-quality 4K content, ensuring an exceptional viewing experience that meets modern standards for visual clarity and detail. Users can store up to 2GB of files internally within the headend.

Key Features:

- **Content Broadcasting:** Effortlessly broadcast content to all guests in real-time, whether in common areas like lobbies or in guest rooms.
- **Dynamic Info-Screens:** Utilise the “info-screen” functionality to display advertisements, announcements or relevant information tailored to your audience.
- **PDF Display Capability:** Show PDF pages from one or multiple files, allowing for presentations, brochures or important notices to be shared visually.
- **Customisable Layouts:** Tailor the display scheme to fit your needs, enabling you to choose how content is presented, whether through single-page displays or multi-page slideshows.
- **User-Friendly Interface:** An intuitive interface makes it easy for hotel staff to upload and manage content without needing extensive technical knowledge.
- **Scheduled Content:** Plan and schedule content to be displayed at specific times, ensuring guests receive timely information.

Output configurations are user-friendly, allowing for seamless integration with different broadcast formats, including IP, QAM and COFDM. This means that the TRIAX Media Player can be deployed in various environments and work alongside existing channels, making it an ideal solution for diverse broadcasting needs.

Art. no.:	License Type
418780	TDcH 2 Media Player license
418781	TDcH 4 Media Player license
418785	TDmH 2 Media Player license
418786	TDmH 4 Media Player license

- **Multi-Language Support:** Cater to a diverse clientele with support for multiple languages, making information accessible to all guests.

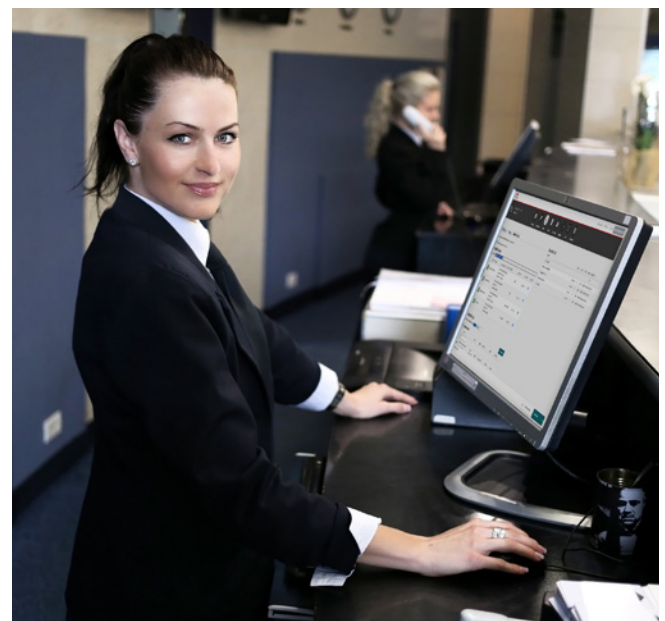

Benefits of Built-In Media Player

- **Enhanced Guest Experience:** Provide guests with relevant information and entertainment options, improving their stay.
- **Effective Advertising:** Promote services, events and local attractions to guests, potentially increasing revenue.
- **Simplified Management:** Streamline content management with a centralised system that reduces the need for multiple devices or platforms.
- **Incorporating the TRIAX headend with its built-in Media Player feature** allows hospitality establishments to create a modern, engaging atmosphere that keeps guests informed and entertained. Whether used for promotional content or important messages, this tool is an essential addition to any hotel or hospitality environment.

Input file types	MP4 / MPG / PDF / TS
Number of simultaneous players	2 or 4 (license based)
Storage size	Internal 2 GB
Output format	MPEG2, H.264, H.265, MP3, AC3, AAC
Output at	IP and QAM / COFDM
Output bandwidth (maximum total)	160 Mbps

Up to 4 individual Media Player channels can be setup for showing /playing different content. Each channel can be setup for different hourly, daily or weekly playout, by the use of the built-in scheduler. A number of files will be played in a loop, according to the individual schedule for each channel.

TRIAX Media Player has the well-known and intuitive Graphical User Interface (GUI) for easy setup and use. It is an integrated part of the existing GUI and offers two levels of users – basic and advanced.

The advanced “admin” user gives the installer or IT department access to the advanced settings, whereas the basic “media” login is simplified for the normal users, e.g. for a receptionist in the hotel who uploads the daily news.

The TRIAX Media Player is available as 2 or 4 media channel licenses, and can be installed on any TDmH /TDcH.

No need for any additional middleware. 30 days free trial period included in all new TDmH / TDcH products. Already installed products may also be upgraded with the new feature by installing SW revision 4.9 or newer (may require license).



HDMI to IP Streaming Server

The TDHI 4H-IP Streamer allows the user to stream any HDMI source over an IP Network to Smart HDTV's or connected computers within the IP Network. It accepts a HDMI input and the unit is designed to deliver a HD/SD IP-stream based on MPEG-2 or H.264 standards. The unit is optimised to be used in combination with the TRIAX IP headends to support multiple HDMI-in sources and includes the required IP-in license to connect the device with the TDMH and TDcH. The TDHI 4HIP HDMI to IP Streamer supports 4 x HDMI inputs that are streamed in 4 separate streams.

Includes:

- 1 x TDHI 4H-IP HDMI to IP Streamer
- 1 x Power Cord
- 1 x User manual
- 1 x 4 IP-in license

Select from the following licenses depending on headend installed - TDX (418047), TDMH (418754), TDcH (418745). License must be ordered for download via License Order Form here:
<https://www.com.com/order-tdmh-tdch-licence/>



HDMI to IP Streaming Server
 Art. No.: .492081

If more than one HDMI streamer is used in one TDMH or TDcH installation, please contact your TRIAX representative for a larger IP-in license option.

Item Name:		HDMI to IP Streaming Server
Art No.		492081
Interfaces		
Ethernet (output)		2 x Ethernet 1Gbps, RJ-45 (Web Management & IP Out)
Video Input		4 x HDMI
Audio Input		4 x HDMI
USB Input		USB 2.0
HDMI Encoding		
Video Format		HD:H.264 AVC/HP@L4.0 ; SD:MPEG-2/MP@ML
Audio Format		MPEG2/AAC
Resolution		HD: 1080P25,1080P30, 1080i 50/60 Max ; SD 480i,576i
Video bitrate		Mbps H.264 or MPEG 2 in range 4 -13
Audio bitrate		Kbps AAC or MPEG-2 in steps between 64 - 38
Input		
Audio bitrate		HDMI: 1080P 25/30, 1080i 50/60 Max
Streaming Protocols		UDP/RTP multicasting, UDP/RTP unicasting
General		
Power Supply		Hz AC 100~240V 50/60
Consumption		W 18
Languages		English
Dimensions		mm 482.6 x 317.5 x 44.45
Weight		Kg 2.80
Rack Mountable		1U height size, fits 19" standard size racks / cabinets
Display		LCD panel
Temperature		°C 5 - 40
Relative Humidity		°C 80% @ 30

MOD404TC - 4x HDMI to RF Modulator

Supporting COFDM (DVB-T) and QAM (DVB-C), 1080p60

Art. No.: 300133



The TRIAX MOD404TC is a versatile quad HDMI modulator designed to distribute high-quality digital audio and video signals over existing coaxial cable networks. It supports up to four HDMI sources, including surveillance cameras, media players, satellite receivers, and computers.

The unit integrates H.264 encoding with selectable DVB-T (COFDM) or DVB-C (QAM) modulation, converting HDMI signals into RF output for reliable distribution to multiple receivers such as TVs or set-top boxes – even across long cable distances.

Key features:

- 4x HDMI Inputs
- Dual Output Modulation: DVB-C / DVB-T (2-in-1 solution)
- Wide Video Resolution Support:
 - Input: 480i/p, 576i/p, 720p, 1080i/p
 - Output: Up to 1080p@50/60Hz
- Output Frequency Range: DVB-T: 177–858 MHz, DVB-C: 105–858 MHz
- Efficient RF Distribution:
 - 2 RF output channels for 4 HDMI sources (2 HDMI sources per RF channel)
- Adjustable RF Output Level:
 - 95 dB μ V minimum
 - 0–30 dB attenuator (1 dB step adjustment)
- High Signal Quality: MER \geq 35 dB
- User-Friendly Control:
 - Integrated LCD display and front-panel buttons
 - Web-based control and firmware updates
- Compact & Rack-Mountable Design
- Preconfigured Default Settings for DVB-C and DVB-T

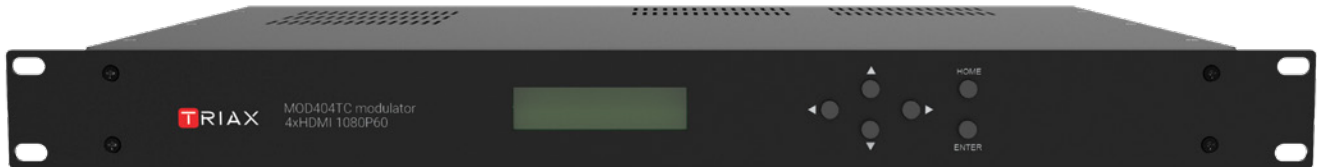

Item Name:		MOD404TC - 4x HDMI to RF Modulator	
Art No.		300133	
Input Channel		4	
Input Connectors		HDMI	
Video System		480i/p, 576i/p, 720p, 1080i/p	
RF OUTPUT			
Type		1 F-type output ports for 2 carriers, 75 Ω	
Frequency	MHz	DVB-T: 177 - 858, DVB-C: 105 - 858	
Output Level	dBuV	95 Min.	
RF Level Adjustment	dB	0 ~ -30	
Attenuation step	dB	1 per step	
MER	dB	35 Min.	
MODULATION			
Video Resolution		1080p 50/60 Max	
Video Compression		H.264 High/Main profile	
Video Bit Rate	Mbps	12 Max.	
Audio Compression		MPEG-2/AAC	
Audio Bit Rate	Kbit/s	192	
Editable Field		Service Name, Service ID, LCN, NIT Version, TS ID, Network Name, Network ID, Original Net ID, Country	
DVB-T			
Standard		DVB-T (ETSI EN 300 744)	
Carrier (OFDM Mode)		2K,8K	
Guard Intervals		1/4, 1/8, 1/16, 1/32	
Code Rate (FEC)		1/2, 2/3, 3/4, 5/6, 7/8	
Constellations		64QAM	
Bandwidth	MHz	6, 7, 8, 7-8	
DVB-C			
Standard		DVB-C (ETSI EN 300 429 V1.2.1)	
Constellation		64QAM	
Symbol rate		2.0 ~ 6.96 Mbs symbols	
Bandwidth	MHz	7, 8	
MANAGEMENT / CONTROL			
Configuration		6 Local keys on Upper cover	
Web Management		RJ-45 Ethernet port	
GENERAL			
Display		LCD panel @ 2 x 16 characters (on front panel)	
Power Supply		AC 100~240V 50/60Hz	
Consumption	W	17	
Languages		English	
Dimensions		19"x12.5"x1.75"	
Weight	kg	2.2	





TDmH Mini Headend

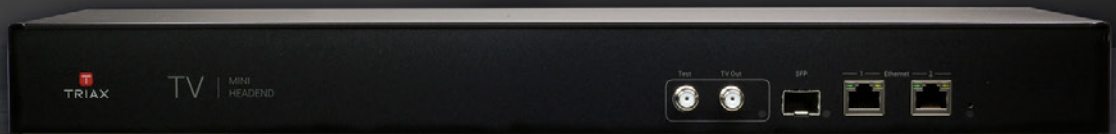



TDmH Mini Headend

Built on the same cutting-edge and well-tested software platform used for TDcH, but with reduced functionality to meet the requests for an entry-level headend. Complimentary updated software offers new and existing customers additional functions, benefits, and powerful hardware configurations to match your requirements.

Compact excellence

- Exquisite engineering, finely tuned for perfect performance
- Your natural choice for swift, efficient TV distribution
- Save time and costs, with fast, easy installation and remote management
- Compact design fits elegantly into 19" racks (1U)
- Reliable, innovative headend expertise from TRIAX

Built-In Media Player

- Users can effortlessly convert various source formats - including photos, videos, presentations and PDF files - into playable transport-streams without the need for external software (SW v4.9.0 or later).

Smooth integration

- Optimised channel setup with advanced multiplexing and Service Pool technology
- Supports SCR Functionality
- No need for retuning TV sets in rooms thanks to SID and PID Management
- EPG Management ensures full Electronic Program Information (EPG) for better user experience
- Central decryption with CI slots, Free-To-Air version available
- Option for scrambling of premium services
DRM compatibility with LG, Philips and Samsung TV sets
- Multiple language service allows for multiple distribution of a service with different audio (language) tracks
- IP-in and IP-out for receiving and streaming services. Possibility for simultaneous IP-in and IP-out through the same interface with optional VLAN tags for separating the in and out streams

Support for SCR Multiswitches

- Increases the number of satellite positions that can be received in the TDcH/TDmH
- Increases the number of international TV services that can be distributed
- Save time, cost and space with minimal cabling; using a TRIAX DCSS LNB eliminates the need for an external multiswitch.
- Reduced hardware for a cost optimised and compact solution

Service Pool and Multiplex technology*

- 8 DVB-S/S2/S2X and 6 DVB-T/T2/C input signals
- 8 QAM or COFDM full band modulators (switchable)
- 48 IP-in SPTS and MPTS UDP/RTP
- 48 IP-out SPTS UDP/RTP
- 4 x CI interfaces for CAM
- Multiplexing at both RF output, IP output, scrambler and CAM (CI interface)
- Optimised service line-up within the available input and output modules
- More relevant TV services due to service multiplexing

Energy saving – long-term reliability

- Low power consumption
- Temperature controlled cooling system with integrated fans - increases the service life of the equipment
- The cooling system supports 19" rack mounting as well as wall mounting

* Features depend on model and license(s)

TDmH Mini Headend technical details



Mini Headend - IP
TDmH IP, Art. No.: 492770



Mini Headend - FTA
TDmH 8S, Art. No.: 492772

	TDmH IP	TDmH 8S	TDmH 8S-I	TDmH 14STC-I
ORDER INFORMATION				
Art. Number [Pro:Idiom (LG) Ready]	492770	492772	492773 [492775]	492774 [492776]
EAN Number [Pro:Idiom (LG) Ready]	5061038081510	5061038081534	5061038081541 [5061038081565]	5061038081558 [5061038081572]
INTERFACES				
Management Interface		1 x 1000 Base-T (RJ 45, Port 1)		
SimulCrypt / DRM		1 x 1000 Base-T (RJ 45, Port 2) not supported with current software release		
Ip-in and -out		1 x 1000 Base-T (SFP)		
CI slots			4 x PCMCIA (front access)	
DVB-S2X input				
Satellite inputs		4 x F connectors, 75 Ω, 400 mA per input LNB power feed		
Number of transponders		8		
Frequency range		950 – 2150 MHz		
Level range		44 – 90 dBμV		
Return loss		> 10dB		
DVB-S modulation		QPSK; 8PSK (16APSK and 32APSK will be supported in later SW version)		
Max. data rate / tuner		83 Mbit/s		
Input selection		DiSEqC 1.0 Control 13/18VDC, 22kHz and SCR via JESS (EN 50607:2015)		
DVB-T/T2/C input				
Terrestrial / Cable input				1 x F connector, 75 Ω
Tuners				6
Input frequency range				47 – 862 MHz
Channel bandwidth				7/8 MHz
Level range				40 – 95 dBμV
Input noise				< 7 dB
Return loss				> 10 dB
DVB-T				
Demodulator type				COFDM
Modulation DVB-T				QPSK, 16QAM, 64QAM
DVB-T2				
Demodulator type				COFDM
Modulation DVB-T2				QPSK, 16QAM, 64QAM, 256QAM
DVB-C				
Demodulator type				QAM
Modulation				16QAM, 64QAM, 128QAM, 256QAM
IP-Input				
Number of IP input streams	48	4, 16 or 48 x SPTS/MPTS (license required)		
Data interface		1 x 1000 Base-T SFP or Fibre SFP ; 1000BaseX (SerDes) mode IEEE802.3 Ethernet, IEEE802.1Q VLAN IGMPv2, IGMPv3		
Protocols		SPTS Streaming (VBR) including PAT, SDT, PMT, CAT and EIT MPTS Streaming (VBR) including PAT, SDT, PMT, CAT and EIT Multicast UDP and RTP MPEG Transport Stream via IP Protocol MPEG		
IP packet format				
IP-Bitrate		max. 950 Mbit/s at SFP interface for all SPTS streams		
CI interfaces				
Bitrate			Configurable: 50, 72, 96Mbps	
PID and service limit			PID and service limit is given by the CAM	
Supply voltage			5V	



Mini Headend - 8S with CI

TDmH 8S-I, Art. No.: 492773

TDmH 8S-I Pro:Idiom (LG) ready, Art. No.: 492775

Mini Headend - 14 STC with CI

TDmH 14STC-I, Art. No.: 492774

TDmH 14STC-I Pro:Idiom (LG) ready, Art. No.: 492776

	TDmH IP	TDmH 8S	TDmH 8S-I	TDmH 14STC-I
RF output				
RF out		1 x F connector		
HF measuring output		1 x F connector, -20 dB		
Frequency range		306 – 862 MHz		
Channels		S 21 – C 69		
Channel settings		8 channels in a row, single channels can be switched off		
Return loss		> 10 dB		
Output impedance		75 Ω		
QAM modulation				
Output level range		85 – 95 dBμV		
Modulation scheme		QAM 16, 32, 64, 128, 256		
Dynamic phase error		< 0.3		
MER		> 43 dB		
Symbol rate		3.5 – 7.2 MS/s		
COFDM modulation				
Output level range		83 – 93 dBμV		
Carrier to spurious ratio:		> 60 dB		
Modulation scheme:		QPSK, 16 QAM, 64 QAM		
MER		≥ 40dB		
Output mode:		2k		
Guard intervals:		1/4, 1/8, 1/16, 1/32		
IPTV Output				
Number of IP output streams		48 x SPTS (license required)		
Data interface		1 x 1000 Base-T SFP or Fibre SFP ; 1000BaseX (SerDes) mode IEEE802.3 Ethernet, IEEE802.1Q VLAN		
Protocols		SPTS Streaming (VBR) including PAT, SDT, PMT, CAT and EIT Multicast UDP and RTP MPEG Transport Stream via IP Protocol 7 TS packets pr. Ethernet packet		
IP packet format		MPEG		
IP-Bitrate		max. 950 Mbit/s at SFP interface for all SPTS streams		
PID-Filtering and Remapping		Yes		
TTL		1-255 (default 16)		
EIT		Inside SPTS for current service		
XML EPG		EPG data in XML format as specified by Samsung Configurable language and Maturity Rating Country for XML EPG		
Scrambling				
VSecure (Philips)				License required 48 x
[Philips TV + special CAM]				
Pro:Idiom (LG)				License required 24 x
Order product code 492775 or 492776				
LYNK (Samsung)				License required 48 x
Features				
SNMP		SNMP traps (license required)		
General				
Mains supply		100 – 264 V AC, 50/60 Hz		
Ground connection		Ground clamp		
Power consumption	typ. 20 W, max. 25 W	typ. *30 W, max. 65 W	typ. *33 W, max. 73 W	typ. *40 W, max. 80 W
* Without CAM and LNB power				
Ambient temperature		-10°C to +50°C		
Dimensions in mm		(W x D x H) 434 x 168 x 45		
Net Weight	2,6 kg	2,8 kg	3,0 kg	3,1 kg



TDcH Compact Headend





TDcH Compact Headend - Strong and stable platform

Built on our cutting edge and well tested software platform, the opportunities with TDcH are endless. Complimentary updated software offers new and existing customers additional functions and benefits, along with powerful hardware configurations to match your requirements.

Compact excellence

- Exquisite engineering, finely tuned for perfect performance
- Your natural choice for swift, efficient TV distribution
- Save time and costs, with fast, easy installation and remote management
- Compact design fits elegantly into 19" racks (2U)
- Reliable, innovative headend expertise from TRIAX

Built-In Media Player

- Users can effortlessly convert various source formats - including photos, videos, presentations and PDF files - into playable transport-streams without the need for external software (SW v4.9.0 or later).

Smooth integration

- Optimised channel setup with advanced multiplexing and Service Pool technology
- Supports SCR Functionality
- No need for retuning TV sets in rooms thanks to SID and PID Management
- EPG Management ensures full Electronic Program Information (EPG) for better user experience
- Central decryption with CI slots, Free-To-Air version available
- Option for scrambling of premium services DRM compatibility with Philips and Samsung TV sets
- Multiple language service allows for multiple distributions of a service with different audio (language) tracks
- IP-in and IP-out for receiving and streaming services. Possibility for simultaneous IP-in and IP-out through the same interface with optional VLAN tags for separating the in and out streams

Support for SCR Multiswitches

- Increases the number of satellite positions that can be received in the TDcH/TDmH
- Increases the number of international TV services that can be distributed
- Save time, cost and space with minimal cabling; using a TRIAX DCSS LNB eliminates the need for an external multiswitch.
- Reduced hardware for a cost optimised and compact solution

Service Pool and Multiplex technology*

- 16 DVB-S/S2/S2X and 6 DVB-T/T2/C input signals
- 16 QAM or COFDM full band modulators (switchable)
- 96 IP-in SPTS and MPTS UDP/RTP
- 100 IP-out SPTS UDP/RTP
- 8 x CI interfaces for CAM
- Multiplexing at both RF output, IP output, scrambler and CAM (CI interface)
- Optimised service line-up within the available input and output modules
- More relevant TV services due to service multiplexing

Energy saving – long-term reliability

- Low power consumption
- Temperature controlled cooling system with integrated fans - increases the service life of the equipment
- The cooling system supports 19" rack mounting as well as wall mounting

* Features depend on model and license(s)

TDcH Compact Headend technical details



Compact Headend - FTA
TDCH 16S, Art. No.: 492791



Compact Headend - S with CI
TDcH 16S-I, Art. No.: 492781

	TDcH 16S	TDcH 16S-I	TDcH 22STC-I
ORDER INFORMATION			
Art. Number	492791	492781	492782
EAN Number	5061038080124	5061038080100	5061038080117
INTERFACES			
Management Interface	1 x 1000 Base-T (RJ 45, Port 1)		
SimulCrypt / DRM	1 x 1000 Base-T (RJ 45, Port 2) not supported with current software release		
Ip-in and -out	1 x 1000 Base-T (SFP)		
CI slots	8 x PCMCIA (front access)		
USB	USB 2.0, Type A conn (Data transfer, additional storage,...) not supported current software release		
DVB-S2X input			
Satellite inputs	4 x F connectors, 75 Ω, 400 mA per input LNB power feed		
Number of transponders	16		
Frequency range	950 – 2150 MHz		
Level range	44 – 90 dBμV		
Return loss	> 10dB		
DVB-S modulation	QPSK; 8PSK (16APSK and 32APSK will be supported in later SW version)		
Max. data rate / tuner	83 Mbit/s		
Input selection	DiSEqC 1.0 Control 13/18VDC, 22kHz and SCR via JESS (EN 50607:2015)		
DVB-T/T2/C input			
Terrestrial / Cable input			1 x F connector, 75 Ω
Tuners			6
Input frequency range			47 – 862 MHz
Channel bandwidth			7/8 MHz
Level range			40 – 95 dBμV
Input noise			< 7 dB
Return loss			> 10 dB
DVB-T			
Demodulator type			COFDM
Modulation DVB-T			QPSK, 16QAM, 64QAM
DVB-T2			
Demodulator type			COFDM
Modulation DVB-T2			QPSK, 16QAM, 64QAM, 256QAM
DVB-C			
Demodulator type			QAM
Modulation			16QAM, 64QAM, 128QAM, 256QAM
IP-Input			
Number of IP input streams	4, 16 or 96 x SPTS/MPTS (license required)		
Data interface	1 x 1000 Base-T SFP or Fibre SFP ; 1000BaseX (SerDes) mode IEEE802.3 Ethernet, IEEE802.1Q VLAN		
Protocols	IGMPv2, IGMPv3 SPTS Streaming (VBR) including PAT, SDT, PMT, CAT and EIT MPTS Streaming (VBR) including PAT, SDT, PMT, CAT and EIT Multicast UDP and RTP MPEG Transport Stream via IP Protocol		
IP packet format	MPEG		
IP-Bitrate	max. 950 Mbit/s at SFP interface for all SPTS streams		
CI interfaces			
Bitrate	Configurable: 50, 72, 96Mbps		
PID and service limit	PID and service limit is given by the CAM		
Supply voltage	5V		



Compact Headend - 22 STC with CI
TDcH 22STC-I, Art. No.: 492782

	TDcH 16S	TDcH 16S-I	TDcH 22STC-I
RF output			
RF out		1 x F connector	
HF measuring output		1 x F connector, -20 dB	
Frequency range		306 – 862 MHz	
Channels		S 21 – C 69	
Channel settings		16 channels in a row, single channels can be switched off	
Return loss		> 10 dB	
Output impedance		75 Ω	
QAM modulation			
Output level range		85 – 95 dBμV	
Modulation scheme		QAM 16, 32, 64, 128, 256	
Dynamic phase error		< 0.3	
MER		> 43 dB	
Symbol rate		3.5 – 7.2 MS/s	
COFDM modulation			
Output level range		83 – 93 dBμV	
Carrier to spurious ratio:		> 60 dB	
Modulation scheme:		QPSK, 16 QAM, 64 QAM	
MER		>=40dB	
Output mode:		2k	
Guard intervals:		1/4, 1/8, 1/16, 1/32	
IPTV Output			
Number of IP output streams		100 x SPTS (license required)	
Data interface		1 x 1000 Base-T SFP or Fibre SFP ; 1000BaseX (SerDes) mode IEEE802.3 Ethernet, IEEE802.1 VLAN	
Protocols		SPTS Streaming (VBR) including PAT, SDT, PMT, CAT and EIT Multicast UDP and RTP MPEG Transport Stream via IP Protocol 7 TS packets pr. Ethernet packet	
IP packet format		MPEG	
IP-Bitrate		max. 950 Mbit/s at SFP interface for all SPTS streams	
PID-Filtering and Remapping		Yes	
TTL		1-255 (default 16)	
EIT		Inside SPTS for current service	
XML EPG		EPG data in XML format as specified by Samsung Configurable language and Maturity Rating Country for XML EPG	
Scrambling			
VSecure (Philips) [Philips TV + special CAM]		License required 48 x	
LYNK (Samsung)		License required 48 x	
Features			
SNMP		SNMP traps (license required)	
Common NIT/SDT/EIT		Option via license	
Stackable		Common GUI plus feature to Common NIT/SDT/EIT Option via license	
General			
Mains supply		100 - 264 V AC, 50/60 Hz	
Ground connection		Ground clamp	
Power consumption	*typ. 32 W, max. 90 W	*typ. 36 W, max. 90 W	*typ. 46 W, max. 90 W
* Without CAM and LNB power			
Ambient temperature		-10°C to +50°C	
Dimensions in mm		(W x D x H) 434 x 220 x 90	
Net Weight	3.77 kg	4.13 kg	4.13 kg



Contact

triaux.com/contact

TRIAX is a global supplier of reliable, innovative products and solutions for the reception and distribution of video, audio and data signals.

Our Products are used in homes, businesses and operator networks by broadcasters, satellite, cable and telecom operators.

Our Solutions combine our hardware and software expertise to deliver value to hospitality and related markets, through a partner network of system integrators, large installers and operators.

TRIAX headquarters are based in Wales, UK, subsidiary office in Dubai, UAE and R&D in Denmark.

The company operates through a dedicated partner network of global distributors.

Copyright © 2026 TRIAX. All rights reserved. The TRIAX Logo and TRIAX, TRIAX Multimedia are registered trademarks or trademarks of the TRIAX Company or its affiliates.

All specifications in this brochure are subject to change without further notice.

5 year limited warranty is effective for TDmH and TDcH products invoiced by TRIAX from 13th May 2025. Terms and Conditions apply.

All trademarks are the property of their respective owners.

04-2026

TDmH / TDcH Media Player Built-in



triaux.com